

CRITICAL AREAS STUDY

Yang Residence: Watercourse Buffer Modification

Prepared for:

Steve and Sophie Yang
6660 East Mercer Way
Mercer Island, WA 98040

Prepared by:



750 Sixth Street South
Kirkland . WA 98033

p 425.822.5242
f 425.827.8136
watershedco.com

November 2018, revised October 2019

The Watershed Company Reference Number: 180605

The Watershed Company Contact Person: Ryan Kahlo, PWS, Senior Ecologist

Cite this document as:

The Watershed Company. October 2019 Revision. Critical Areas Study, Yang Residence.



TABLE OF CONTENTS

	Page #
1 Introduction	3
2 Existing Conditions	3
2.1 Setting.....	3
2.2 Watercourse A.....	4
2.3 Watercourse Buffers.....	5
2.4 Lake Washington Shoreline	7
2.5 Wildlife Habitat Conservation Areas.....	9
3 Regulations	9
3.1 Local Critical Areas Regulations	9
3.2 Local Shoreline Master Program Regulations	9
4 Project Purpose and Approach	10
4.1 Watercourse A Buffer Averaging.....	10
4.2 Mitigation Sequencing.....	11
5 Shoreline Regulations	12
6 Impact Assessment	13
7 Buffer Enhancement Plan	15
7.1 Overview.....	15
7.2 Goals.....	15
7.3 Performance Standards.....	15
7.4 Monitoring Methods.....	16
7.5 Construction Notes and Specifications.....	17
7.6 Maintenance	17
7.7 Material Specifications and Definitions.....	18
8 Summary	19

Appendix A

Buffer Averaging and Restoration Plan

Appendix B

Bond Quantity Worksheet

LIST OF FIGURES

Figure 1. A vicinity map showing the approximate location of the site (source: King County iMAP).....4

Figure 2. An aerial view of the subject property (source: King County iMAP).....5

Figure 3: Existing residence and Watercourse A buffer, facing northeast (6/18/2018) .6

Figure 4: Location of Watercourse A (immediately adjacent house), facing east (6/18/2018).....6

Figure 5: Watercourse A buffer reduction area (located within house footprint), facing west (6/18/2018).7

Figure 6: Overlapping shoreline and watercourse buffer, facing southeast (3/18/2018)..8

Figure 7: Lake Washington shoreline buffer, facing southeast (3/18/2018).....8

LIST OF TABLES

Table 1: Summary showing no net loss of critical area buffer functions with proposed conditions..... 14

CRITICAL AREAS REPORT

YANG RESIDENCE

1 INTRODUCTION

This critical area study is prepared as part of a proposal to permit proposed site improvements at 6660 E Mercer Way in Mercer Island, Washington (parcel number 2396000050). Proposed site improvements include the replacement and partial relocation of the existing single-family residence.

The site contains one piped watercourse and the Lake Washington shoreline. The applicant proposes buffer averaging to reduce the standard 25-foot watercourse watercourse buffer, while also reducing the developed area within the buffer and locating the new residence farther from the shoreline, in accordance with the Mercer Island Shoreline Master Program (SMP). This report is intended to satisfy the requirements of the Mercer Island City Code (MICC). It provides a description of existing site conditions, proposed watercourse buffer averaging, proposed buffer enhancement, and mitigation sequencing to ensure no net loss of critical area or buffer functions.

2 EXISTING CONDITIONS

2.1 Setting

The subject property (Parcel #2396000050) is located at 6660 E Mercer Way in Mercer Island, Washington; in Section 30, Township 24 North, Range 5 East of the Public Land Survey System. The property is approximately 0.41 acres in size and situated in the Mercer Island sub-basin of the Cedar-Sammamish Watershed (Water Resource Inventory Area [WRIA] 8; Figure 1). The subject parcel is zoned residential (R-8.4).

The subject parcel currently includes an existing 2,670-square foot single-family residence with attached garage built in 1978, a paved driveway, scattered ornamental plantings, and areas composed of bare dirt and gravel. The property slopes moderately downhill from west to east, leaving the existing house situated several feet below the driveway entry point. The only access to the property is via an ingress/egress easement through several adjacent properties to the west. The easement extends off of SE 68th Street through Parcels #2396000-0020, -0030, & -0040.

The entire parcel is mapped as Kitsap silt loam, two to eight percent slopes, by the Natural Resources Conservation Service (NRCS) Web Soil Survey (USDA 2017). One

pipled watercourses, referred to for the purpose of this report as Watercourse A, and the Lake Washington shoreline are located on the property (Figure 2). No other critical areas are present on the property.



Figure 1. A vicinity map showing the approximate location of the site (source: King County iMAP).

2.2 Watercourse A

Watercourse A on the subject property is an entirely pipled watercourse located adjacent to the southern property boundary. The pipled watercourse is conveyed beneath the existing driveway, along the edge of the existing residence, finally discharging into Lake Washington near the southeast property corner.

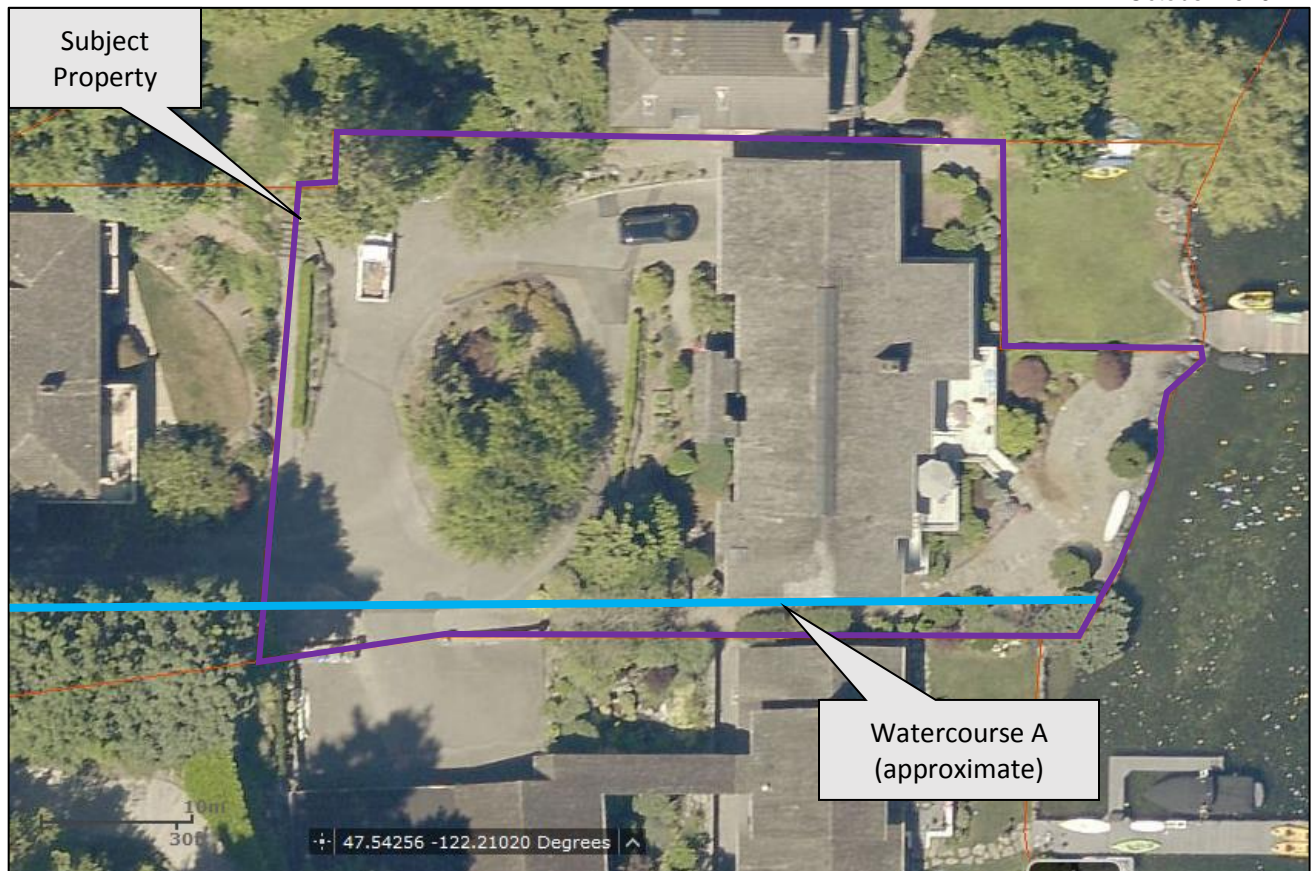

Figure 2. An aerial view of the subject property (source: King County iMAP).

2.3 Watercourse Buffers

The buffer areas associated with Watercourse A are highly degraded. The Watercourse A buffer area is nearly entirely unvegetated. Impervious surfaces, including the driveway and existing residence, comprise the majority of the watercourse buffer. East of the existing residence, the buffer is mostly unvegetated gravel mixed with a few rhododendron shrubs, a Japanese black pine, and other ornamental plantings. Immediately west of the house, a small area dominated by ornamental shrubs and a cypress tree that has been topped to maintain views for neighboring properties.



Figure 3: Existing residence and Watercourse A buffer, facing northeast (6/18/2018).



Figure 4: Location of Watercourse A (immediately adjacent house), facing east (6/18/2018).



Figure 5: Watercourse A buffer reduction area (located within house footprint), facing west (6/18/2018).

2.4 Lake Washington Shoreline

The existing shoreline area is mostly gravel with a stone foot path. A few ornamental shrubs are present in the shoreline buffer, but vegetation is generally sparse or absent. A riprap bulkhead is located at the edge of the shoreline. An existing dock and lawn area is located on a shared property adjacent the northeast corner of the subject property. The existing residence is located at the edge of the 25-foot shoreline buffer. The southern portion of the shoreline buffer overlaps with the Watercourse A buffer. The lake is considered a shoreline of the state, and on the subject property is designated as Urban Residential under the SMP.



Figure 6: Overlapping shoreline and watercourse buffer, facing southeast (6/18/2018)



Figure 7: Lake Washington shoreline buffer, facing southeast (6/18/2018).

2.5 Wildlife Habitat Conservation Areas

The only non-aquatic wildlife habitat conservation areas designated by the City of Mercer Island are specific to those areas used by bald eagles for nesting, breeding, feeding, and survival. Lake Washington is a common feeding area for bald eagles, but no known bald eagle nests are documented in the vicinity of the subject property. No bald eagle nests were visually observed in the vicinity, either.

3 REGULATIONS

3.1 Local Critical Areas Regulations

In the City of Mercer Island, watercourses are regulated under the Mercer Island City Code (MICC), Chapter 19.07 – Environment. Watercourse buffers are designated based on the watercourse classification (MICC 19.07.070). Watercourses in Mercer Island are classified as one of four types based on fish use, permanence of flow, and whether the watercourse is piped. Watercourse A is piped for its entire length on the subject property. Piped watercourses require a standard buffer with of 25 feet.

Watercourse buffers may be averaged in accordance with MICC 19.07.070.B.3, provided the following criteria are satisfied:

- a. *The proposal will result in a net improvement of critical area function;*
- b. *The proposal will include replanting of the averaged buffer using native vegetation;*
- c. *The total area contained in the averaged buffers on the development proposal site is not decreased below the total area that would be provided if the maximum width were not averaged;*
- d. *The standard buffer width is not reduced to a width that is less than the minimum buffer width at any location; and*
- e. *That portion of the buffer that has been reduced in width shall not contain a steep slope.*

3.2 Local Shoreline Master Program Regulations

Projects located within 200 feet of shorelines of the state (Lake Washington) are also regulated under the Mercer Island Shoreline Master Program (MICC 19.07.110). Single-family residences in the Urban Residential shoreline designation are allowed under a Shoreline Exemption. All structures in the shoreline zone must be set back at least 25 feet from the OHWM. The maximum impervious surface coverage allowed is

10% between 0 and 25 feet from the OHWM and 30% between 25 and 50 feet from the OHWM (MICC 19.07.110.E.1, Table C). Additionally, legal nonconforming uses and structures may continue, and structures 25 feet landward from the OHWM that were legally created may be maintained, repaired, renovated, remodeled and completely replaced to the extent that nonconformance is not increased (MICC 19.07.110.B.1).

4 PROJECT PURPOSE AND APPROACH

The purpose of the project is to remove and reconstruct an existing single-family residence. In order to achieve the purpose of the project and protect the shoreline, watercourse, and buffer areas located on the property, the new residence will be located farther from Watercourse A and the Lake Washington OHWM and will incorporate enhancement of the averaged watercourse buffer areas. The proposed buffer averaging will result in a significant improvement in buffer functions by replacing areas of impervious and otherwise degraded buffer with a dense, native shrub and groundcover community. The proposed project will result in a net decrease of impervious area within the watercourse buffer.

Much of the new residence will be located within the footprint of the existing residence. Those parts of the new residence not located within the existing footprint will be located farther from the critical area buffers than the existing structure. However, due to the extent of buffer encumbrances on the property, the proposed residence cannot be constructed without buffer modification. Therefore, the project will incorporate buffer averaging.

4.1 Watercourse A Buffer Averaging

The applicant is proposing to reduce a portion of the Watercourse A buffer to a minimum of 10.89 feet. The buffer reduction area is within a portion of the buffer currently within the footprint of the existing structure, which extends all the way to Watercourse A.

The following provisions must be addressed under the requirements of MICC 19.07.070.B.3:

- a. *The proposal will result in a net improvement of critical area function;*

The existing buffer is degraded throughout, with sparsely vegetated or unvegetated areas and/or impervious surfaces comprising the entire on-site buffer. Native vegetation is nearly absent in the buffer. The proposed project will result in a substantial improvement of buffer functions. A total of 1,279 SF of impervious surface will be removed from the Watercourse A buffer, including 812 SF of existing structure and 467 SF of existing driveway. The entire structure, which is presently located directly adjacent the watercourse, will be moved farther away from Watercourse A. With the exception of the buffer

reduction area, the new residence will be located outside of the standard 25-foot buffer. Impervious areas within the buffer will be removed and replaced with a dense assemblage of native trees, shrubs and groundcovers. In total, 3,624 SF of degraded and sparsely vegetated watercourse buffer and 1,350 SF of overlapping shoreline and watercourse buffer will be enhanced with a native plant community.

- b. *The proposal will include replanting of the averaged buffer using native vegetation;*

The entire averaged buffer will be planted with native vegetation.

- c. *The total area contained in the averaged buffers on the development proposal site is not decreased below the total area that would be provided if the maximum width were not averaged;*

The reduced buffer will be replaced with an expanded buffer farther east at a 1:1 ratio. The averaged buffer will be of equivalent size as the standard buffer. In total, 374 SF of buffer will be reduced, and 375 SF of buffer will be added east of the proposed residence, providing a larger buffer for both Watercourse A and the Lake Washington shoreline.

- d. *The standard buffer width is not reduced to a width that is less than the minimum buffer width at any location; and*

Piped watercourses do not have a minimum buffer width under MICC. However, the proposal will maintain a minimum 10.75-foot buffer at the narrowest point. This width will ensure that a vegetated buffer will remain in the unlikely scenario that Watercourse A is daylighted in the future, and it is a similar minimum width as previously authorized buffer reduction proposals for piped watercourses on Mercer Island.

- e. *That portion of the buffer that has been reduced in width shall not contain a steep slope.*

There are no steep slopes on the subject property.

4.2 Mitigation Sequencing

The project has been designed to avoid, minimize and compensate for impacts to the greatest extent possible given the constraints of the site. The following describes how the mitigation sequencing requirements of the MICC have been met.

Avoid

The project area contains a watercourse, watercourse buffer, and shoreline buffer. Direct impacts to critical areas will be avoided. New buffer impacts will be avoided through

buffer averaging and site design. No impacts or structural modifications to the shoreline buffer are proposed. Buffer averaging will be applied to avoid impacts to the Watercourse A buffer. The driveway cannot be relocated entirely outside of the buffers, as the existing ingress/egress easement to the property also provides ingress/egress to the adjacent property to the south. However, the size of the driveway within the buffer will be substantially reduced. A total of 467 SF of driveway area will be removed and planted with native vegetation. Only the minimum driveway area necessary for access and per fire code will remain.

Minimize

The amount of buffer averaging proposed is the minimum necessary to accommodate the proposed development. Impacts to the reduced critical areas buffers will result from relocation of the new structure. The new residence will be farther from the lakeshore and Watercourse A. Impervious areas within the buffer will be reduced by 1,279 SF. The project was designed to be as far from Watercourse A as feasible, while allowing for a suitable home design that is similar in size and scope as neighboring properties.

Mitigate

Compensatory mitigation is not applicable, as buffer averaging will allow the development to avoid buffer impacts. The averaged buffer will provide substantially greater function than the existing buffer by removing impervious surfaces and locating the new residence farther from the piped watercourse and the shoreline. To ensure the greatest uplift in function possible, the entire averaged buffer will be planted with a dense, native tree, shrub community, and groundcover community. While large trees are not proposed, due to the proximity to the residence and to maintain the required view corridors for adjacent property owners, the proposed native small tree, shrub, and groundcover community will provide much greater protective functions for Watercourse A if it is ever daylighted.

Monitor

A five-year monitoring and maintenance plan is proposed to ensure the success of planted mitigation areas over time.

5 SHORELINE REGULATIONS

Under MICC 19.07.110.E, a 25-foot buffer is applied from the Lake Washington Shoreline, which is designated Urban Residential on the subject property. Maximum 10 percent impervious surface is allowed within 25 feet of the OHWM. A maximum 30 percent impervious surface coverage is allowed between 25 feet and 50 feet of the OHWM. The proposed residence will be located entirely beyond the 50-foot setback. No impervious surfaces are proposed within the 50-foot setback, and no modifications to the bulkhead or areas waterward of the OHWM are proposed.

6 IMPACT ASSESSMENT

The proposal is to construct a new single-family residence and attached garage. The proposed development cannot be completed within the constraints of the standard watercourse buffer. In total, 374 SF of buffer is proposed for reduction on the south side of the existing and proposed structure. An equivalent buffer area will be added on the east side of the existing/proposed structure, which will provide additional buffer protections for both the watercourse and the shoreline, as the watercourse and shoreline buffers will overlap. Currently, the existing house is located up to the edge of Watercourse A. The proposed residence will be 10.75 from Watercourse A at the closest point. The proposed residence will also be located approximately 20 feet farther from the Lake Washington shoreline. Approximately 3,693 SF of the averaged Watercourse A buffer and 1,350 SF of the shoreline buffer, which partially overlaps the watercourse buffer, will be enhanced with native vegetation to ensure buffer function improvement.

No Net Loss

Even without enhancement, hydrologic, water quality, and habitat function would be improved under the proposed project due to the increasing of the minimum buffer widths and the removal of impervious surfaces. The buffer averaging and restoration plan (see Appendix A) is designed to ensure an improvement in ecological function in all buffer areas as a result of the proposed project.

The existing watercourse buffer provides very little protective functions. Proposed mitigation will benefit on-site buffer functions by reducing the amount of impervious surface area in the buffer and increasing the ability of the buffer vegetation to store/trap sediments and nutrients, reduce peak runoff velocities, and improve wildlife habitat. Watercourse A will not be directly affected by the proposed activities, but indirect effects will represent an overall improvement if the watercourse is daylighted in the future. Under such a scenario, shade and allochthonous input of organic material into to the watercourse from the proposed mitigation plantings would be increased. Peak stormwater flows will be reduced by reducing impervious areas in the buffer. Incorporating compost into the soil will improve the absorption capacity of the soil, and the dense native plant community will provide vertical structure to reduce peak runoff volumes. Forage and cover opportunities for wildlife will be improved by the addition of fruit and nut producing native vegetation and increasing the vegetative density. The direct and indirect effects of the proposed reconstruction and mitigation measures will result in a net improvement of on-site critical area and buffer.

Table 1 below summarizes how the proposed mitigation will achieve no net loss of ecological functions on-site.

Table 1: Summary showing no net loss of critical area buffer functions with proposed conditions.

Critical Area Buffer Function	Existing Conditions	Proposed Conditions	Determination
Water Quality	<p>The current water quality function of the watercourse buffer is limited by impervious surfaces and otherwise sparsely vegetated buffer areas. The lakeshore buffer is narrow and mostly unvegetated gravel, which provides very little overall function.</p>	<p>Vegetated buffer width to be expanded, and vegetative density to be substantially increased in through planting of native shrubs and groundcovers. Impervious surfaces will be removed from buffer.</p>	<p>Increasing amount of dense, rigid vegetation will improve the ability to slow surface water flowing towards the watercourse and lakeshore and help filter and capture nutrients and sediments that might otherwise enter the waterbodies. In the unlikely event that the piped watercourse is ever daylighted, this ability of the buffer to provide these functions will be increased as they would provide shade which helps reduce water temperatures and maintain dissolved oxygen levels. The proposed condition represent a net improvement over the current condition.</p>
Hydrology	<p>The current hydrologic function of the critical area buffers is limited by impervious and otherwise sparsely vegetated areas, which provide very little attenuation of stormwater flows.</p>	<p>Vegetated buffer width to be expanded. Vegetative density to be substantially increased in critical area buffers through planting of native shrubs and groundcovers. Compost will be incorporated into the compact, nutrient-poor soil. Impervious area to be decreased in the buffers.</p>	<p>The addition of dense shrubs and groundcover plants will help attenuate flood flow during heavy rain events. Incorporation of compost into the compact soils will increase the permeability and infiltration capacity of the buffers, further reducing surface runoff volumes. In the unlikely event that the piped watercourse segments are ever daylighted, this ability of the buffer to provide these functions will be increased.</p>
Habitat	<p>The habitat function of the critical area buffers is limited by the presence of the existing residence very little vegetation, lack of native plants, vegetative density, and low structural diversity</p>	<p>Vegetated buffer width and vegetative density/diversity to be significantly increased in critical area buffers through planting of native shrubs and groundcover.</p>	<p>Increasing native shrub and groundcover plants will increase vegetative density and structural diversity, improving cover and forage opportunities for wildlife. The diversity of habitat niches will be improved with increasing structural complexity and density.</p>

<p>Overall</p>	<p>Low functioning critical area buffer exists in the project area. Existing vegetated areas are characterized by a very sparsely vegetated understory. Other buffer areas are completely unvegetated and/or are existing impervious areas.</p>	<p>Reduction in impervious area, increasing the vegetated buffer width, decompaction and incorporation of compost into soil profile, planting of dense shrubs and groundcover in existing vegetated and unvegetated watercourse buffer areas.</p>	<p>The proposed project is expected to improve ecological functions over existing conditions, which are highly degraded. This includes habitat, hydrology, and water quality functions of the critical area buffers. Overall an improvement in functions is expected.</p>
-----------------------	---	---	---

7 BUFFER ENHANCEMENT PLAN

7.1 Overview

A comprehensive five-year maintenance and monitoring plan is included as part of the buffer enhancement. The plan specifies appropriate species for planting and planting techniques, describes proper maintenance activities, and sets forth performance standards to be met yearly during monitoring. This will ensure that enhancement/restoration plantings will be maintained, monitored, and successfully established within the first five years following implementation.

Proposed restoration begins with incorporating compost into the enhancement area. This will be followed by installation of native shrub and groundcover species suitable to the site (Appendix A). Ten native small tree/shrub species and five native groundcover species are proposed in the mitigation area. Native plantings are intended to increase native plant cover, improve native species diversity, increase vegetative structure, and provide food and other habitat resources for wildlife.

Specifications for items in **bold** can be found under Section 7.7, "Material Specifications and Definitions."

7.2 Goals

1. Enhance shoreline and watercourse buffers.
 - a. Reduce the amount of impervious surface area within watercourse buffers.
 - b. Establish dense and diverse native small tree, shrub, and groundcover vegetation throughout the mitigation areas.

7.3 Performance Standards

The standards listed below will be used to judge the success of the plan over time. If the standards are met at the end of the five-year monitoring period, the City shall issue release of the performance bond.

1. Survival:

- a. 100% survival of all installed trees and shrubs at the end of Year One. This standard may be met through establishment of installed plants or by replanting as necessary to achieve the required numbers.
 - b. 80% survival of all installed trees and shrubs at the end of Year Two. This standard may be met through establishment of installed plants or by replanting as necessary to achieve the required numbers.
 - i. Survival beyond Year Two is difficult to track. Therefore, a diversity standard is proposed in place of survival (see #3, below).
2. Native vegetation cover in planted areas:
- a. Achieve at least 60% cover of native plants by the end of Year 3. Volunteer species may count toward this standard. Total native plant cover must include a minimum of 40% tree and shrub cover.
 - b. Achieve at least 80% cover of native plants by the end of Year 5. Volunteer species may count toward this standard. Total native plant cover must include a minimum of 60% tree and shrub cover.
3. Species diversity in planted areas:
- a. Establish at least six native small tree/shrub species and four native groundcover species throughout the enhancement areas by Year 5. Volunteer species may count toward this standard. "Establishment" is considered at least five healthy, individual plants of a given species present within the mitigation areas.
4. Invasive species standard: No more than 10% cover of invasive species in the planting area in any monitoring year. Invasive species are defined as any Class A, B, or C noxious weeds as listed by the King County Noxious Weed Control Board.

7.4 Monitoring Methods

This monitoring program is designed to track the success of the mitigation site over time by measuring the degree to which the performance standards listed above are being met. An as-built plan will be prepared within 30 days of substantially complete construction of the mitigation areas. The as-built plan will document conformance with these plans and will disclose any substitutions or other non-critical departures. The as-built plan will establish baseline plant installation quantities and photopoints, which will be used throughout the monitoring period to document the site progression.

Monitoring will occur twice annually for five years. The first monitoring visit will take place in the spring. This visit will record necessary weeding, invasive control, and other maintenance needs. The **restoration specialist** will then notify the owner and/or maintenance crews of necessary early season maintenance. The late-season visit will occur in late summer or fall and will record the following and be submitted in an annual report to the City:

1. General summary of the spring visit.

2. First- and second-year counts of surviving and dead/dying plants by species in the planting areas.
3. Estimates of native species cover using cover class method.
4. Estimates of invasive species cover using cover class method.
5. Counts of established native species to determine species richness.
6. Photographic documentation at permanent photopoints.
7. Intrusions into the planting areas, erosion, vandalism, trash, and other actions detrimental to the overall health of the mitigation areas.
8. Recommendations for maintenance in the mitigation areas.
9. Recommendations for replacement of all dead or dying plant material with same or like species and number as on the approved plan.

7.5 Construction Notes and Specifications

General Notes

The **restoration specialist** will oversee the following:

1. Clearing, soil decompaction, and compost incorporation;
2. Invasive weed clearing; and
3. Plant material inspection.
 - a) Plant delivery inspection.
 - b) 50% plant installation/layout inspection.
 - c) 100% plant installation inspection.

Work Sequence

1. Clear the planting area of all invasive woody vegetation including but not limited to Himalayan blackberry, English ivy, and English laurel.
2. Roto-till 2 inches of **compost** into the upper 8 inches of the soil.
3. All plant installation will take place during the dormant season (October 15th to March 1st).
4. Layout vegetation to be installed per the planting plan and plant schedule.
5. Prepare a planting pit for each plant and install per the planting details.
6. Mulch each tree and shrub with a circular **wood chip mulch** ring, 4 inches thick and extending 9 inches from the base of the plant (18-inch diameter).

7.6 Maintenance

This site will be maintained for five years following completion of the plant installation.

1. Replace each plant found dead in the summer monitoring visit during the upcoming fall dormant season (October 15th to March 1st).
2. Follow the recommendations noted in the spring monitoring site visit.
3. Invasive species maintenance plan:
 - a) Himalayan blackberry, English ivy, English laurel, and other invasive woody vegetation will be grubbed out by hand on an ongoing basis, with care taken to grub out roots except where such work will jeopardize the roots of installed or volunteer native plants.
 - b) If it is likely that hand removal will not be completely effective or will damage desirable species, then application of an herbicide approved for use in aquatic areas may be used. Herbicide applications must be conducted only by a state-licensed applicator. Applications should be done between mid-spring and mid-summer to maximize uptake by plants. Application should be a targeted method such as spot spray (preferred for Himalayan blackberry), or wick.
4. At least twice yearly, remove by hand all competing weeds and weed roots from beneath each installed plant and any desirable volunteer vegetation to a distance of 12 inches from the main plant stem. Weeding should occur as needed during the spring and summer. Frequent weeding will result in lower mortality and lower plant replacement costs.
5. Do not weed the area near the plant bases with string trimmer (weed whacker). Native plants are easily damaged or killed, and weeds easily recover after trimming.
6. Mulch the weeded areas beneath each plant with **wood chip mulch** as necessary to maintain a minimum 4-inch-thick, 18-inch-diameter mulch ring.
7. Ensure that supplemental irrigation is supplied to the entire planting area from June 1st – September 30th. A total of one inch of water per week should be applied during this time.

7.7 Material Specifications and Definitions

1. **Compost:** Cedar Grove Compost or equivalent product. 100% vegetable compost with no appreciable quantities of sand, gravel, sawdust, or other non-organic materials. Quantity required: 56 cubic yards.
2. **Restoration specialist:** The Watershed Company [(425) 822-5242] personnel or other person qualified to evaluate environmental restoration projects.
3. **Wood chip mulch:** Chipped woody material approximately 1 inch minimum to 3 inches in maximum dimension (not sawdust or coarse hog fuel). Mulch shall not contain appreciable quantities of garbage, plastic, metal, soil, and dimensional lumber or construction/ demolition debris. Pacific Topsoil [(800) 844-7645] sells suitable woodchip mulch called “Wood Chip Mulch” at many of their locations. Note: Arborist woodchips generally contain weed seeds and are not a reliable alternative. Quantity required: 4 cubic yards.

8 SUMMARY

The applicant proposes the removal and reconstruction of a single-family residence, located partially within areas a piped watercourse buffer. In order to avoid development within buffer areas, buffer averaging is proposed under MICC 19.07.070.A.3. In conjunction with buffer averaging, the averaged buffer will be enhanced through the installation of native plantings; decompaction of the existing soil surface combined with compost soil amendment, removal of 1,279 SF of impervious surface, and constructing the new residence farther from the watercourse and shoreline buffer.

The reduction of impervious surfaces, installation of mitigation plantings, soil decompaction and amendment within the critical area buffers will increase water quality, hydrology, and habitat functions. The proposed planting plan incorporates a diversity of native plant species, including small trees, shrubs, and groundcover plants. The proposed plan will provide better protection of the on-site critical area functions and values than exists under current conditions.

Finally, a comprehensive five-year maintenance and monitoring plan has been prepared. This plan will ensure that proposed enhancement plantings will be maintained, monitored, and successfully established within the first five years following implementation. Overall, a net improvement in on-site critical area functions and values is the expected result of the project.

APPENDIX A

**Buffer Averaging and Restoration
Plan**

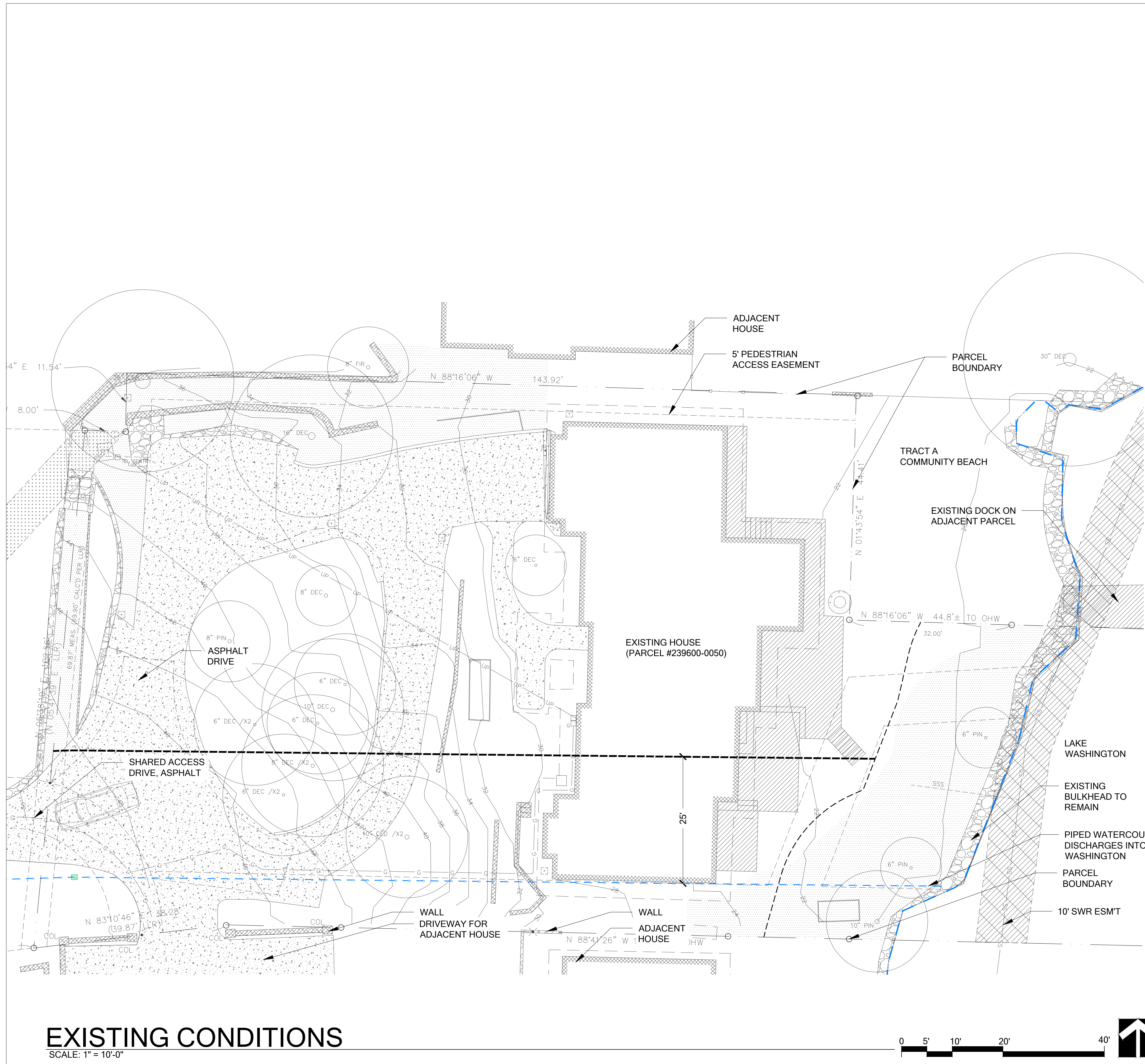

EXISTING CONDITIONS

SCALE: 1" = 10'-0"

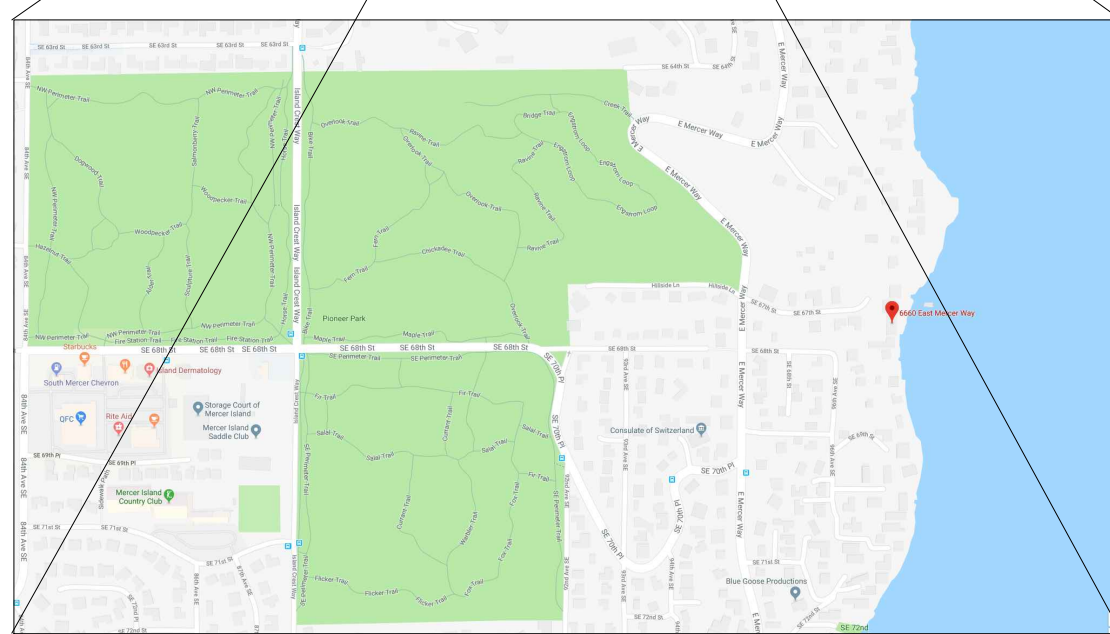
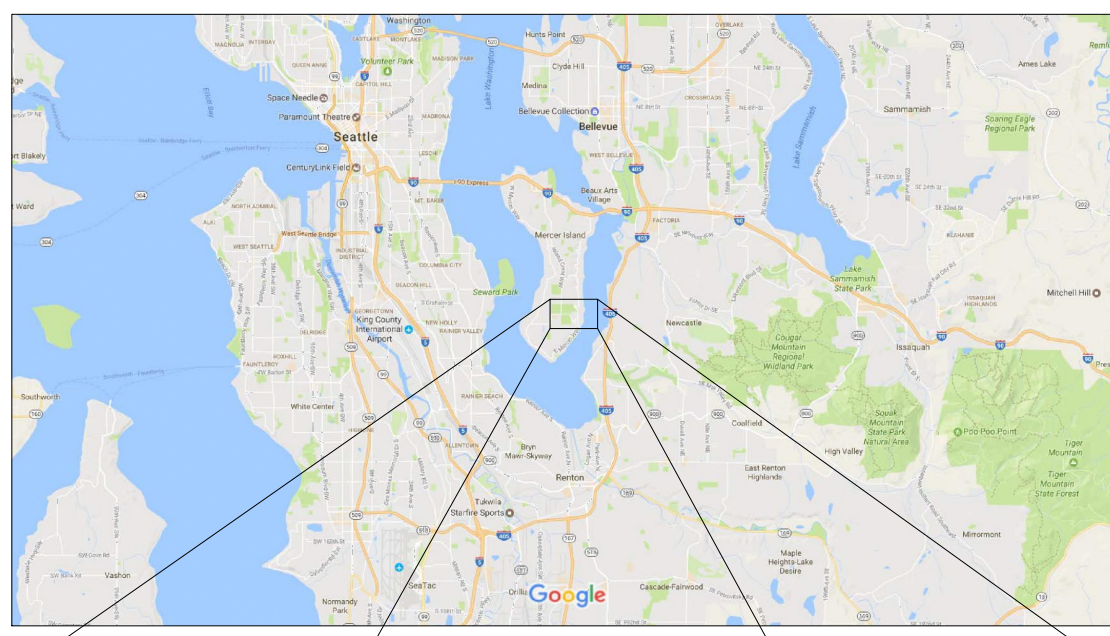
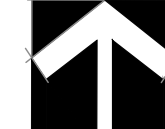

VICINITY MAPS

SHEET INDEX

- 1 EXISTING CONDITIONS
- 2 IMPACTS ASSESSMENT
- 3 MITIGATION PLAN
- 4 SITE PREPARATION PLAN
- 5 PLANTING PLAN
- 6 PLANT INSTALLATION DETAILS AND NOTES
- 7 MITIGATION PLAN NOTES

NOTES

1. CRITICAL AREAS DELINEATED BY THE WATERSHED COMPANY ON JUNE 19, 2018.
2. SURVEY PERFORMED DECEMBER 2017, BY TERRANE, 10801 MAIN STREET, SUITE 102, BELLEVUE, WA 98004. (425)-458-4488
3. VERTICAL DATUM: NAD88

LEGEND

- OHWM (FROM OTHERS)
- PIPED WATERCOURSE
- SHORELINE BUFFER
- WATERCOURSE BUFFER

YANG RESIDENCE BUFFER AVERAGING PLAN PREPARED FOR STEVE AND SOPHIE YANG 6660 EAST MERCER WAY MERCER ISLAND, WA 98040

SUBMITTALS & REVISIONS	
NO.	DESCRIPTION
1	07-11-2019 REVIEW SET
2	10-04-2019 REVISIONS TO CITY COMMENTS

SHEET SIZE:
 ORIGINAL PLAN IS 22" x 34".
 SCALE ACCORDINGLY.

PROJECT MANAGER: RK
DESIGNED: RK/KMB/GM
DRAFTED: GM
CHECKED: RK/KMB
JOB NUMBER: 180605
SHEET NUMBER: W1 OF 7



Know what's below.
 Call before you dig.

**YANG RESIDENCE
BUFFER AVERAGING PLAN
PREPARED FOR
STEVE AND SOPHIE YANG
6660 EAST MERCER WAY
MERCER ISLAND, WA 98040**

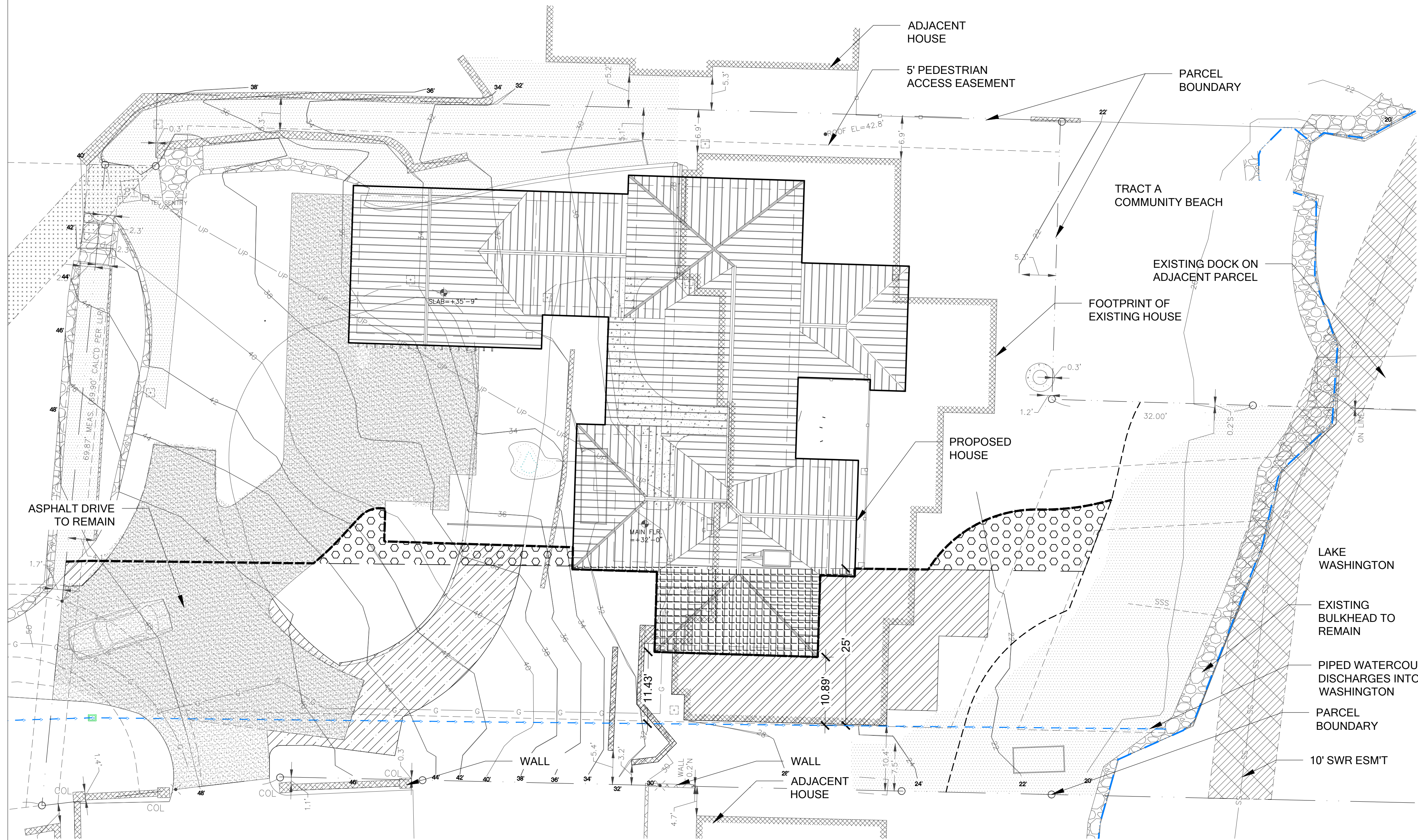

LEGEND

- OHWM (FROM OTHERS)
 - PIPED WATERCOURSE
 - SHORELINE BUFFER
 - PROPOSED WATERCOURSE BUFFER
- WATERCOURSE B BUFFER IMPACTS**
- BUFFER TO BE REDUCED (374 SF)
 - BUFFER TO BE ADDED (375 SF)
 - REDUCTION OF STRUCTURE WITHIN BUFFER (812 SF)
 - IMPERVIOUS TO BE REMOVED FROM BUFFER (467 SF)

IMPACTS ASSESSMENT

SCALE: 1" = 10'-0"

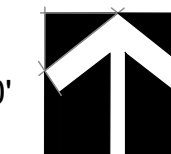

Know what's below.
Call before you dig.

SUBMITTALS & REVISIONS	
NO.	DESCRIPTION
1	07-11-2019 REVIEW SET
2	10-04-2019 REVISIONS TO CITY COMMENTS

SHEET SIZE:
ORIGINAL PLAN IS 22" x 34".
SCALE ACCORDINGLY.

PROJECT MANAGER: RK
DESIGNED: RK/KMB/GM
DRAFTED: GM
CHECKED: RK/KMB
JOB NUMBER:

180605
SHEET NUMBER:
W2 OF 7

**YANG RESIDENCE
BUFFER AVERAGING PLAN
PREPARED FOR
STEVE AND SOPHIE YANG
6660 EAST MERCER WAY
MERCER ISLAND, WA 98040**



LEGEND

- OHWM (FROM OTHERS)
- PIPED WATERCOURSE
- SHORELINE BUFFER
- PROPOSED WATERCOURSE BUFFER
- WATERCOURSE BUFFER MITIGATION FOR ALLOWED RECONSTRUCTION WITHIN BUFFER
- BUFFER ENHANCEMENT (3,624 SF)
- SHORELINE ENHANCEMENT AREA (1,350 SF)
- EXISTING BULKHEAD TO REMAIN
- PIPED WATERCOURSE, DISCHARGES INTO LAKE WASHINGTON
- OWNER SELECTED LANDSCAPE AREA
- EXISTING TREE TO REMAIN

MITIGATION PLAN

SCALE: 1" = 10'-0"

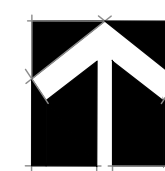

Know what's below.
Call before you dig.

SUBMITTALS & REVISIONS	
NO.	DESCRIPTION
1	07-11-2019 REVIEW SET
2	10-04-2019 REVISIONS TO CITY COMMENTS

SHEET SIZE:
ORIGINAL PLAN IS 22" x 34".
SCALE ACCORDINGLY.

PROJECT MANAGER: RK
DESIGNED: RK/KMB/GM
DRAFTED: GM
CHECKED: RK/KMB
JOB NUMBER:

180605
SHEET NUMBER:

W3 OF 7

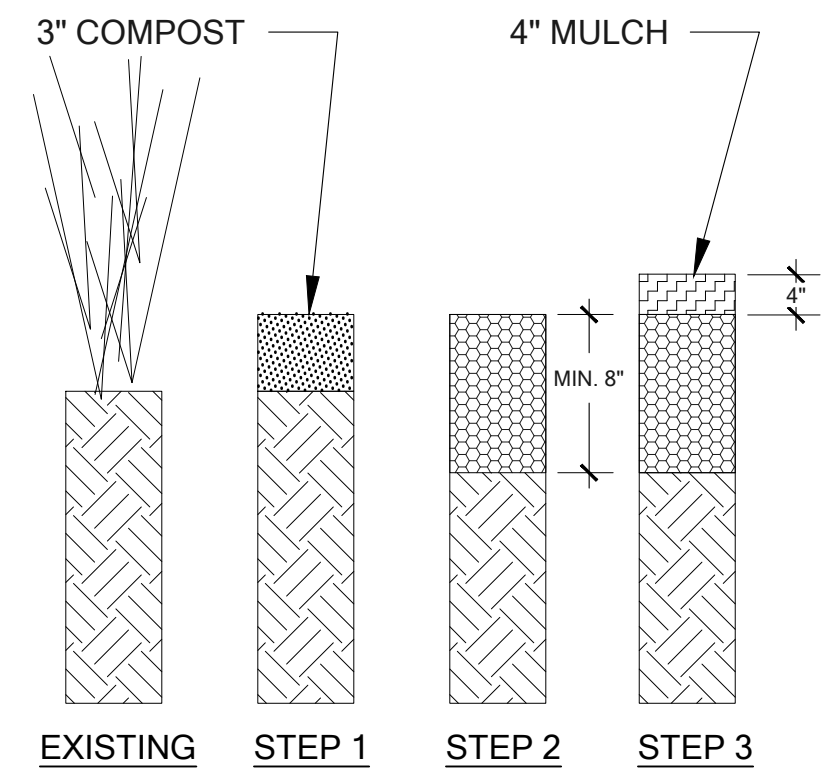

PLANTING AREA PREPARATION
STEP 1
 REMOVE UNDESIRABLE SPECIES. WORK WITHIN EXISTING ROOT ZONES SHALL BE DONE BY HAND.
 PLACE THREE (3) INCHES COMPOST.
STEP 2
 INCORPORATE COMPOST TO AN EIGHT (8) INCH DEPTH.
STEP 3
 INSTALL MULCH LAYER FOUR (4) INCHES DEEP AND INSTALL PLANTS. (SEE PLANTING DETAIL.)

SOIL PREPARATION: AMEND EXISTING SOILS
 SEQUENCE OF WORK - NOT TO SCALE

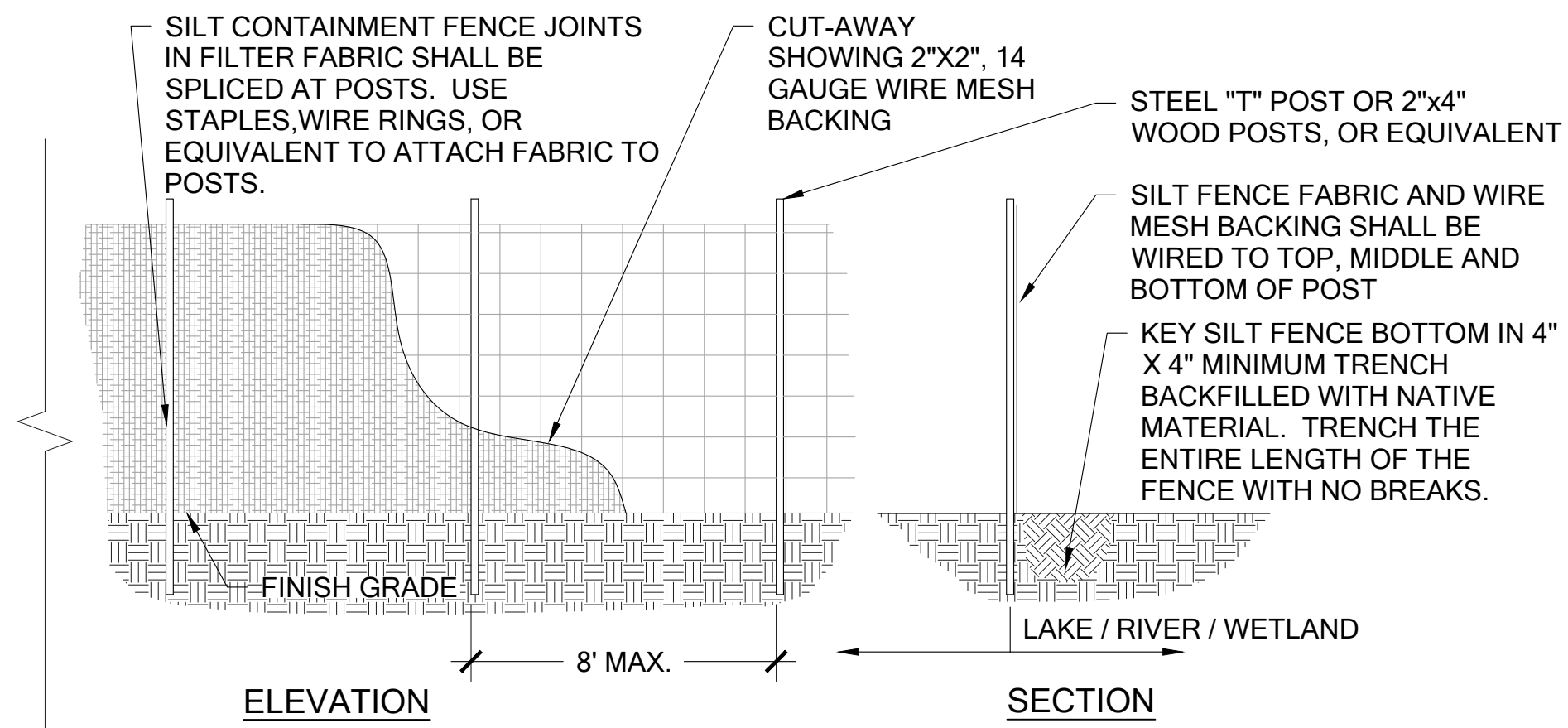

1 SILT FENCE

Scale: NTS

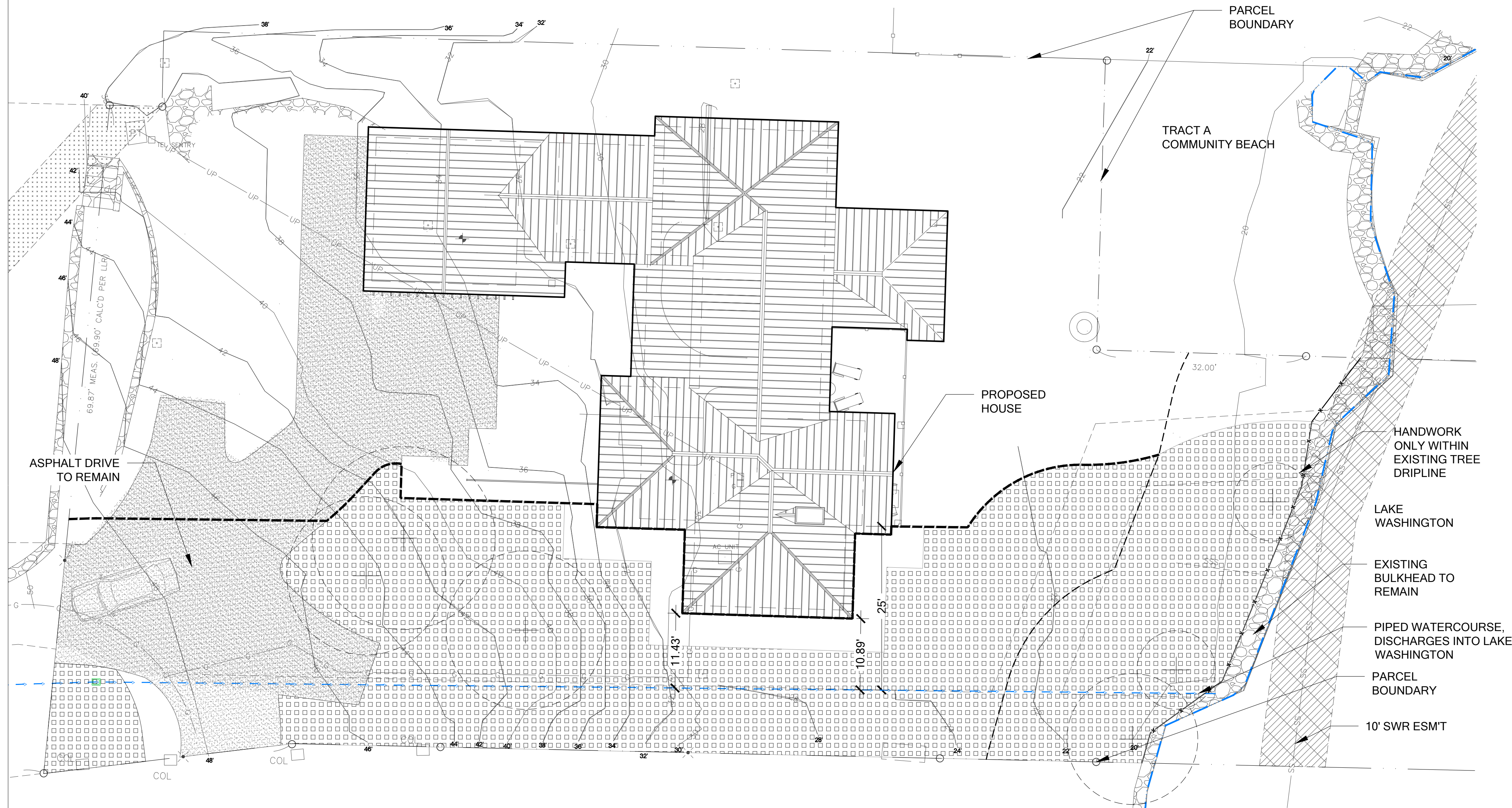

NOTES

- SILT FENCE SHALL BE INSTALLED PRIOR TO ANY CONSTRUCTION ACTIVITIES.
- ANY DAMAGE SHALL BE REPAIRED IMMEDIATELY.
- SEDIMENT SHALL BE REMOVED WHEN ACCUMULATION EXCEEDS 6" IN DEPTH.
- TOP DRESS SOIL BY HAND WITH COMPOST MULCH WITHIN DRIPLINES OF EXISTING TREES TO REMAIN.

LEGEND

- OHWM (FROM OTHERS)
- PIPED WATERCOURSE
- SHORELINE BUFFER
- PROPOSED WATERCOURSE BUFFER
- REDUCED WATERCOURSE B BUFFER
- SOIL PREPARATION AREA (4,973 SF)
- SILT FENCE, 73 LF (DETAIL 1 SHEET W4)

SITE PREPARATION PLAN

SCALE: 1" = 10'-0"

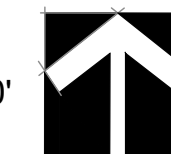

Know what's below.
Call before you dig.

© Copyright - The Watershed Company

**YANG RESIDENCE
 BUFFER AVERAGING PLAN
 PREPARED FOR
 STEVE AND SOPHIE YANG
 6660 EAST MERCER WAY
 MERCER ISLAND, WA 98040**

SUBMITTALS & REVISIONS

NO.	DATE	DESCRIPTION	BY	GM
1	07-11-2019	REVIEW SET	GM	AAM
2	10-04-2019	REVISIONS TO CITY COMMENTS		

SHEET SIZE:
 ORIGINAL PLAN IS 22" x 34".
 SCALE ACCORDINGLY.

PROJECT MANAGER: RK
 DESIGNED: RK/KMB/GM
 DRAFTED: GM
 CHECKED: RK/KMB
 JOB NUMBER:

180605
 SHEET NUMBER:
W4 OF 7

ENHANCEMENT NATIVE MIX PLANTING SCHEDULE (3,304 SF)

VIEW PRESERVATION NATIVE PLANT MIX (1,740 SF)

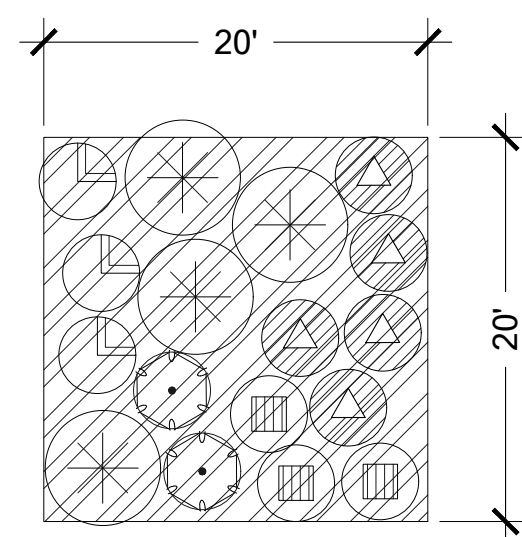

TREES	QTY	SPACING	SIZE
ACER CIRCINATUM / VINE MAPLE	9	8'	1 GAL. MIN.
RHAMNUS PURSHIANA / CASCARA	6	8'	1 GAL. MIN.
SHRUBS			
CORNUS SERICEA / RED-OSIER DOGWOOD	33	6'	1 GAL. MIN.
SYMPHORICARPUS ALBUS / SNOWBERRY	25	4'	1 GAL. MIN.
RIBES SANGUINEUM / RED-FLOWERING CURRANT	17	4'	1 GAL. MIN.
VIBURNUM EDULE / HIGHBUSH CRANBERRY	42	4'	1 GAL. MIN.
VACCINIUM OVATUM / EVERGREEN HUCKLEBERRY	25	4'	1 GAL. MIN.
GROUNDCOVER			
*ALL SPECIES TO BE SPACED TRIANGULARLY			
		48" O.C.	
MAHONIA NERVOSA / DULL MAHONIA	120		4" POT MIN.
POLYSTICHUM MUNITUM / SWORD FERN	120		4" POT MIN.
397 TOTAL			

SHRUBS	QTY	SPACING	SIZE
*ALL SPECIES TO BE SPACED TRIANGULARLY NOTE: GROUP INTO SAME SPECIES CLUSTERS OF 6-8			
SPIRAEA DENSIFLORA	74	3'	1 GAL. MIN.
GAULTHERIA SHALLON / SALAL	74	3'	1 GAL. MIN.
CORNUS SERICEA 'KELSEY'	74	3'	1 GAL. MIN.
GROUNDCOVER			
*ALL SPECIES TO BE SPACED TRIANGULARLY NOTE: GROUP INTO SAME SPECIES CLUSTERS OF 9-15			
DELPHINIUM MENZIESII / WESTERN LARKSPUR	167	24" O.C.	4" POT MIN.
FESTUCA IDAHOENSIS / ROEMER'S FESCUE	167	24" O.C.	4" POT MIN.
ARCTOSTAPHYLOS UVA-URSI / KINNICKINICK	167	24" O.C.	4" POT MIN.
723 TOTAL			

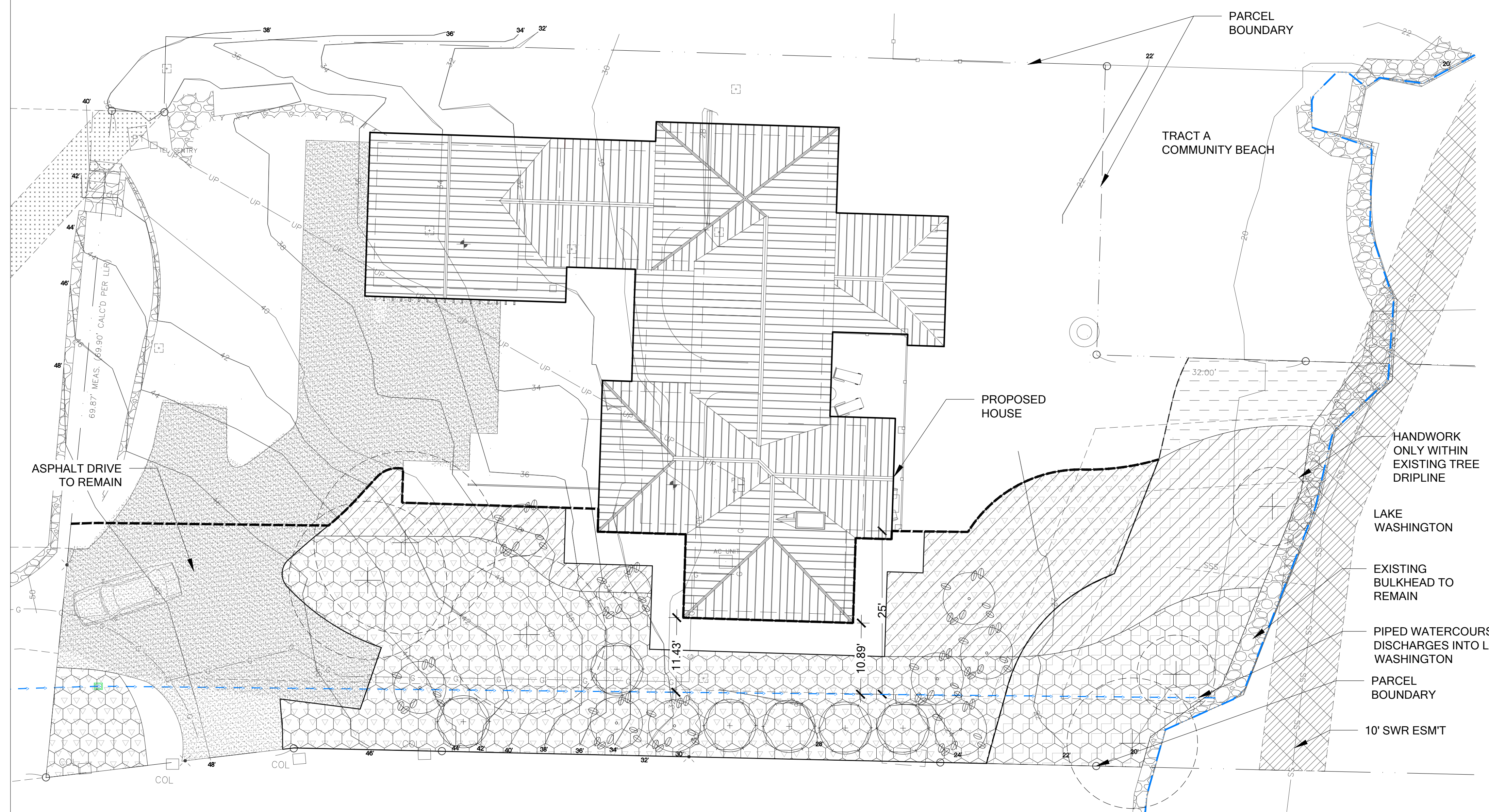

- NOTES**
1. APPLICABLE EROSION CONTROL MEASURES SHALL BE INSTALLED PRIOR TO ANY CONSTRUCTION ACTIVITIES.
 2. REFER TO DETAIL 2, SHEET W6 FOR PLANT SPACING LAYOUT.
 3. REFER TO DETAIL 1, SHEET W6 FOR CONTAINER PLANTING DETAIL.
 4. INSTALL SHRUBS AROUND EXISTING TREES (6), TO REMAIN. PLANT ONLY GROUNDCOVERS WITHIN THE DRIPLINES OF EXISTING TREES TO REMAIN.
 5. FINAL PLANT PLACEMENT SHOULD BE DETERMINED BY RESTORATION SPECIALIST OR LANDSCAPE DESIGNER.

LEGEND

- OHWM (FROM OTHERS)
- PIPED WATERCOURSE
- SHORELINE BUFFER
- PROPOSED WATERCOURSE BUFFER
- WATERCOURSE BUFFER PLANTING AREA (3,624 SF)
NUMBER OF PLANTS WITHIN AREA = 703
- SHORELINE SETBACK NATIVE PLANTING AREA (1,350 SF)
EQUALS 83% OF TOTAL SHORELINE AREA (1,627 SF)
- OWNER SELECTED LANDSCAPE AREA (277 SF)
- EXISTING TREE TO REMAIN
- BUFFER ENHANCEMENT NATIVE PLANTS
- VIEW PRESERVATION NATIVE PLANTS

**YANG RESIDENCE
BUFFER AVERAGING PLAN
PREPARED FOR
STEVE AND SOPHIE YANG
6660 EAST MERCER WAY
MERCER ISLAND, WA 98040**

SUBMITTALS & REVISIONS

NO.	DATE	DESCRIPTION	BY	GM
1	07-11-2019	REVIEW SET		GM
2	10-04-2019	REVISIONS TO CITY COMMENTS		AAH

SHEET SIZE:
ORIGINAL PLAN IS 22" x 34".
SCALE ACCORDINGLY.

PROJECT MANAGER: RK
DESIGNED: RK/KMB/GM
DRAFTED: GM
CHECKED: RK/KMB
JOB NUMBER: 180605
SHEET NUMBER: W5 OF 7

PLANTING PLAN
SCALE: 1" = 10'-0"



PLANT INSTALLATION SPECIFICATIONS

GENERAL NOTES

QUALITY ASSURANCE

- PLANTS SHALL MEET OR EXCEED THE SPECIFICATIONS OF FEDERAL, STATE, AND LOCAL LAWS REQUIRING INSPECTION FOR PLANT DISEASE AND INSECT CONTROL.
- PLANTS SHALL BE HEALTHY, VIGOROUS, AND WELL-FORMED, WITH WELL DEVELOPED, FIBROUS ROOT SYSTEMS, FREE FROM DEAD BRANCHES OR ROOTS. PLANTS SHALL BE FREE FROM DAMAGE CAUSED BY TEMPERATURE EXTREMES, LACK OR EXCESS OF MOISTURE, INSECTS, DISEASE, AND MECHANICAL INJURY. PLANTS IN LEAF SHALL BE WELL FOLIATED AND OF GOOD COLOR. PLANTS SHALL BE HABITUATED TO THE OUTDOOR ENVIRONMENTAL CONDITIONS INTO WHICH THEY WILL BE PLANTED (HARDENED-OFF).
- TREES WITH DAMAGED, CROOKED, MULTIPLE OR BROKEN LEADERS WILL BE REJECTED. WOODY PLANTS WITH ABRASIONS OF THE BARK OR SUN SCALD WILL BE REJECTED.
- NOMENCLATURE: PLANT NAMES SHALL CONFORM TO FLORA OF THE PACIFIC NORTHWEST BY HITCHCOCK AND CRONQUIST, UNIVERSITY OF WASHINGTON PRESS, 1973 AND/OR TO A FIELD GUIDE TO THE COMMON WETLAND PLANTS OF WESTERN WASHINGTON & NORTHWESTERN OREGON, ED. SARAH SPEAR COOKE, SEATTLE AUDUBON SOCIETY, 1997.

DEFINITIONS

- PLANTS/PLANT MATERIALS. PLANTS AND PLANT MATERIALS SHALL INCLUDE ANY LIVE PLANT MATERIAL USED ON THE PROJECT. THIS INCLUDES BUT IS NOT LIMITED TO CONTAINER GROWN, B&B OR BAREROOT PLANTS; LIVE STAKES AND FASCINES (WATTLES); TUBERS, CORMS, BULBS, ETC...; SPRIGS, PLUGS, AND LINERS.
- CONTAINER GROWN. CONTAINER GROWN PLANTS ARE THOSE WHOSE ROOTBALLS ARE ENCLOSED IN A POT OR BAG IN WHICH THAT PLANT GREW.

SUBSTITUTIONS

- IT IS THE CONTRACTOR'S RESPONSIBILITY TO OBTAIN SPECIFIED MATERIALS IN ADVANCE IF SPECIAL GROWING, MARKETING OR OTHER ARRANGEMENTS MUST BE MADE IN ORDER TO SUPPLY SPECIFIED MATERIALS.
- SUBSTITUTION OF PLANT MATERIALS NOT ON THE PROJECT LIST WILL NOT BE PERMITTED UNLESS AUTHORIZED IN WRITING BY THE RESTORATION CONSULTANT.
- IF PROOF IS SUBMITTED THAT ANY PLANT MATERIAL SPECIFIED IS NOT OBTAINABLE, A PROPOSAL WILL BE CONSIDERED FOR USE OF THE NEAREST EQUIVALENT SIZE OR ALTERNATIVE SPECIES, WITH CORRESPONDING ADJUSTMENT OF CONTRACT PRICE.
- SUCH PROOF WILL BE SUBSTANTIATED AND SUBMITTED IN WRITING TO THE CONSULTANT AT LEAST 30 DAYS PRIOR TO START OF WORK UNDER THIS SECTION.

INSPECTION

- PLANTS SHALL BE SUBJECT TO INSPECTION AND APPROVAL BY THE RESTORATION CONSULTANT FOR CONFORMANCE TO SPECIFICATIONS, EITHER AT TIME OF DELIVERY ON-SITE OR AT THE GROWER'S NURSERY. APPROVAL OF PLANT MATERIALS AT ANY TIME SHALL NOT IMPAIR THE SUBSEQUENT RIGHT OF INSPECTION AND REJECTION DURING PROGRESS OF THE WORK.
- PLANTS INSPECTED ON SITE AND REJECTED FOR NOT MEETING SPECIFICATIONS MUST BE REMOVED IMMEDIATELY FROM SITE OR RED-TAGGED AND REMOVED AS SOON AS POSSIBLE.
- THE RESTORATION CONSULTANT MAY ELECT TO INSPECT PLANT MATERIALS AT THE PLACE OF GROWTH. AFTER INSPECTION AND ACCEPTANCE, THE RESTORATION CONSULTANT MAY REQUIRE THE INSPECTED PLANTS BE LABELED AND RESERVED FOR PROJECT. SUBSTITUTION OF THESE PLANTS WITH OTHER INDIVIDUALS, EVEN OF THE SAME SPECIES AND SIZE, IS UNACCEPTABLE.

MEASUREMENT OF PLANTS

- PLANTS SHALL CONFORM TO SIZES SPECIFIED UNLESS SUBSTITUTIONS ARE MADE AS OUTLINED IN THIS CONTRACT. HEIGHT AND SPREAD DIMENSIONS SPECIFIED REFER TO MAIN BODY OF PLANT AND NOT BRANCH OR ROOT TIP TO TIP. PLANT DIMENSIONS SHALL BE MEASURED WHEN THEIR BRANCHES OR ROOTS ARE IN THEIR NORMAL POSITION.
- WHERE A RANGE OF SIZE IS GIVEN, NO PLANT SHALL BE LESS THAN THE MINIMUM SIZE AND AT LEAST 50% OF THE PLANTS SHALL BE AS LARGE AS THE MEDIAN OF THE SIZE RANGE. (EXAMPLE: IF THE SIZE RANGE IS 12" TO 18", AT LEAST 50% OF PLANTS MUST BE 15" TALL.)

SUBMITTALS

PROPOSED PLANT SOURCES

- WITHIN 45 DAYS AFTER AWARD OF THE CONTRACT, SUBMIT A COMPLETE LIST OF PLANT MATERIALS PROPOSED TO BE PROVIDED DEMONSTRATING CONFORMANCE WITH THE REQUIREMENTS SPECIFIED. INCLUDE THE NAMES AND ADDRESSES OF ALL GROWERS AND NURSERIES.

PRODUCT CERTIFICATES

- PLANT MATERIALS LIST - SUBMIT DOCUMENTATION TO CONSULTANT AT LEAST 30 DAYS PRIOR TO START OF WORK UNDER THIS SECTION THAT PLANT MATERIALS HAVE BEEN ORDERED. ARRANGE PROCEDURE FOR INSPECTION OF PLANT MATERIAL WITH CONSULTANT AT TIME OF SUBMISSION.
- HAVE COPIES OF VENDOR'S OR GROWERS' INVOICES OR PACKING SLIPS FOR ALL PLANTS ON SITE DURING INSTALLATION. INVOICE OR PACKING SLIP SHOULD LIST SPECIES BY SCIENTIFIC NAME, QUANTITY, AND DATE DELIVERED (AND GENETIC ORIGIN IF THAT INFORMATION WAS PREVIOUSLY REQUESTED).

DELIVERY, HANDLING, & STORAGE

NOTIFICATION

CONTRACTOR MUST NOTIFY CONSULTANT 48 HOURS OR MORE IN ADVANCE OF DELIVERIES SO THAT CONSULTANT MAY ARRANGE FOR INSPECTION.

PLANT MATERIALS

- TRANSPORTATION - DURING SHIPPING, PLANTS SHALL BE PACKED TO PROVIDE PROTECTION AGAINST CLIMATE EXTREMES, BREAKAGE AND DRYING. PROPER VENTILATION AND PREVENTION OF DAMAGE TO BARK, BRANCHES, AND ROOT SYSTEMS MUST BE ENSURED.
- SCHEDULING AND STORAGE - PLANTS SHALL BE DELIVERED AS CLOSE TO PLANTING AS POSSIBLE. PLANTS IN STORAGE MUST BE PROTECTED AGAINST ANY CONDITION THAT IS DETRIMENTAL TO THEIR CONTINUED HEALTH AND VIGOR.
- HANDLING - PLANT MATERIALS SHALL NOT BE HANDLED BY THE TRUNK, LIMBS, OR FOLIAGE BUT ONLY BY THE CONTAINER, BALL, BOX, OR OTHER PROTECTIVE STRUCTURE, EXCEPT BAREROOT PLANTS SHALL BE KEPT IN BUNDLES UNTIL PLANTING AND THEN HANDLED CAREFULLY BY THE TRUNK OR STEM.
- LABELS - PLANTS SHALL HAVE DURABLE, LEGIBLE LABELS STATING CORRECT SCIENTIFIC NAME AND SIZE. TEN PERCENT OF CONTAINER GROWN PLANTS IN INDIVIDUAL POTS SHALL BE LABELED. PLANTS SUPPLIED IN FLATS, RACKS, BOXES, BAGS, OR BUNDLES SHALL HAVE ONE LABEL PER GROUP.

WARRANTY

PLANT WARRANTY

PLANTS MUST BE GUARANTEED TO BE TRUE TO SCIENTIFIC NAME AND SPECIFIED SIZE, AND TO BE HEALTHY AND CAPABLE OF VIGOROUS GROWTH.

REPLACEMENT

- PLANTS NOT FOUND MEETING ALL OF THE REQUIRED CONDITIONS AT THE CONSULTANT'S DISCRETION MUST BE REMOVED FROM SITE AND REPLACED IMMEDIATELY AT THE CONTRACTOR'S EXPENSE.
- PLANTS NOT SURVIVING AFTER ONE YEAR TO BE REPLACED AT THE CONTRACTOR'S EXPENSE.

PLANT MATERIAL

GENERAL

- PLANTS SHALL BE NURSERY GROWN IN ACCORDANCE WITH GOOD HORTICULTURAL PRACTICES UNDER CLIMATIC CONDITIONS SIMILAR TO OR MORE SEVERE THAN THOSE OF THE PROJECT SITE.
- PLANTS SHALL BE TRUE TO SPECIES AND VARIETY OR SUBSPECIES. NO CULTIVARS OR NAMED VARIETIES SHALL BE USED UNLESS SPECIFIED AS SUCH.

QUANTITIES

SEE PLANT LIST ON ACCOMPANYING PLANS AND PLANT SCHEDULES.

ROOT TREATMENT

- CONTAINER GROWN PLANTS (INCLUDES PLUGS): PLANT ROOT BALLS MUST HOLD TOGETHER WHEN THE PLANT IS REMOVED FROM THE POT, EXCEPT THAT A SMALL AMOUNT OF LOOSE SOIL MAY BE ON THE TOP OF THE ROOTBALL.
- PLANTS MUST NOT BE ROOT-BOUND; THERE MUST BE NO CIRCLING ROOTS PRESENT IN ANY PLANT INSPECTED.
- ROOTBALLS THAT HAVE CRACKED OR BROKEN WHEN REMOVED FROM THE CONTAINER SHALL BE REJECTED.

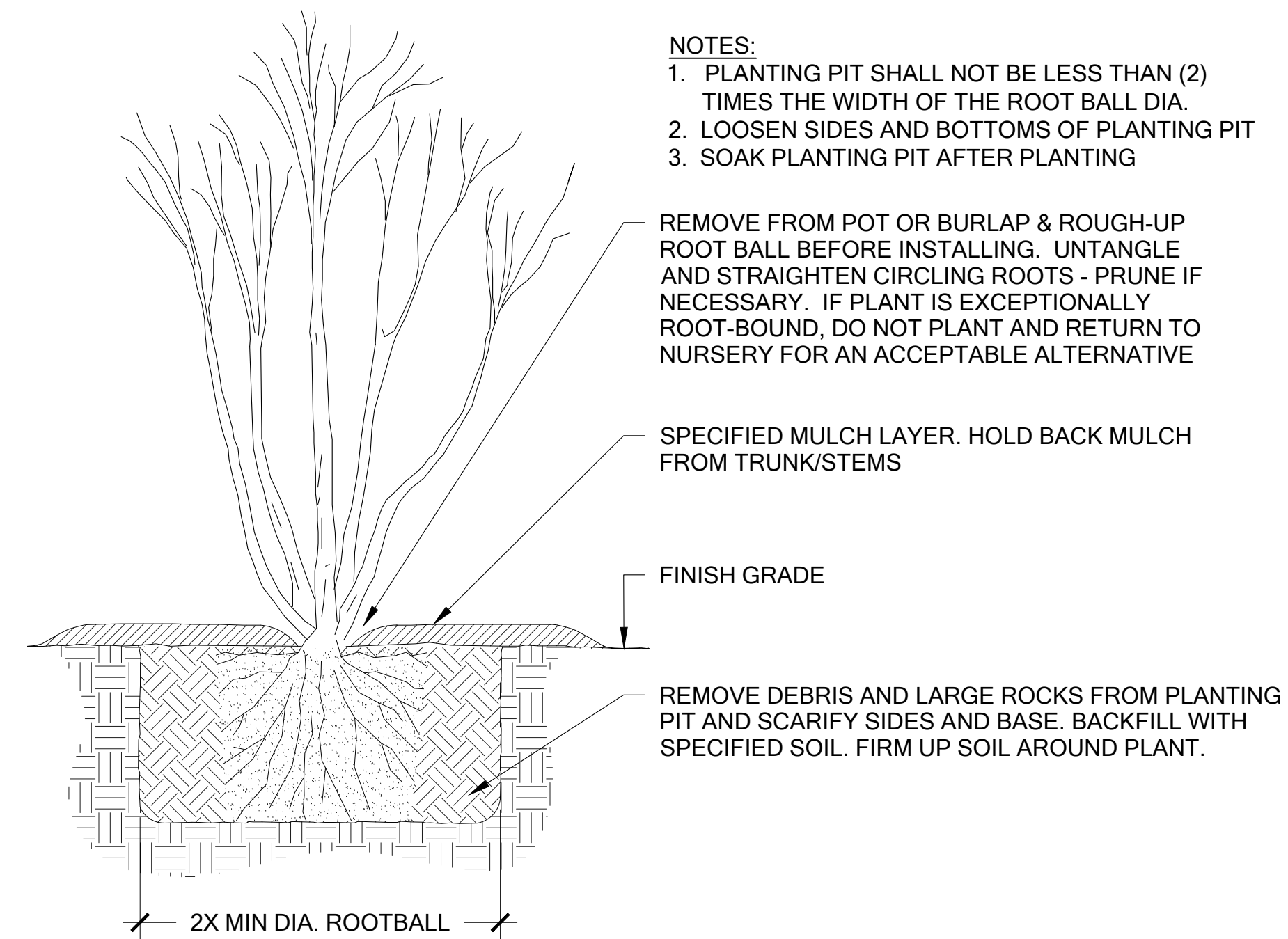

NOTES:

- PLANTING PIT SHALL NOT BE LESS THAN (2) TIMES THE WIDTH OF THE ROOT BALL DIA.
- LOOSEN SIDES AND BOTTOMS OF PLANTING PIT
- SOAK PLANTING PIT AFTER PLANTING

1 TREE AND SHRUB PLANTING

Scale: NTS

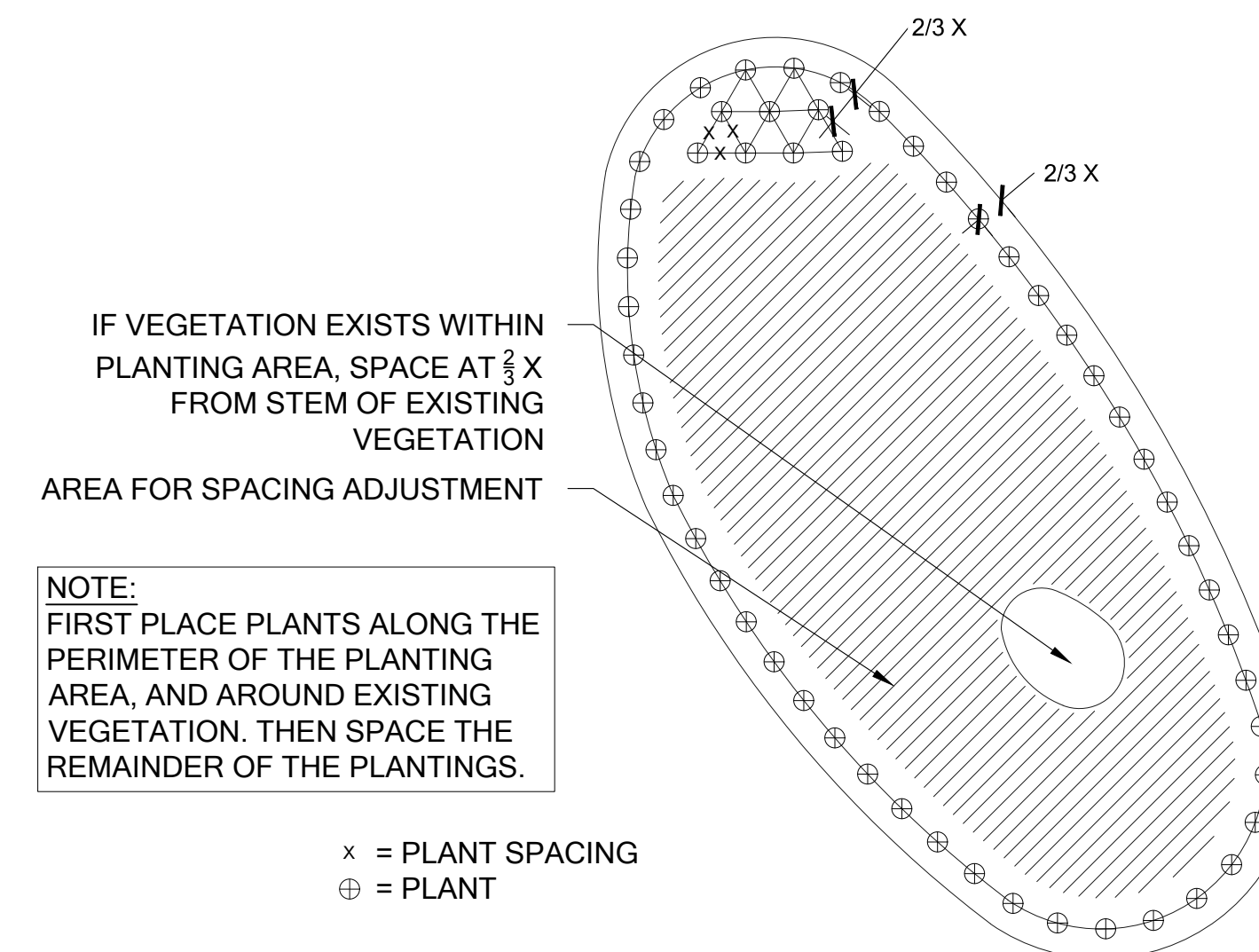

2 PLANT SPACING

Scale: NTS

PLANT INSTALLATION DETAILS AND NOTES

SCALE AS NOTED

YANG RESIDENCE
BUFFER AVERAGING PLAN
PREPARED FOR
STEVE AND SOPHIE YANG
6660 EAST MERCER WAY
MERCER ISLAND, WA 98040

SUBMITTALS & REVISIONS		NO.	DATE	DESCRIPTION	BY
	REVIEW SET	1	07-11-2019		GM
	REVISIONS TO CITY COMMENTS	2	10-04-2019		AAM

SHEET SIZE:
ORIGINAL PLAN IS 22" x 34".
SCALE ACCORDINGLY.

PROJECT MANAGER: RK
DESIGNED: RK/KMB/GM
DRAFTED: GM
CHECKED: RK/KMB

JOB NUMBER:
180605

SHEET NUMBER:
W6 OF 7



Know what's below.
Call before you dig.

MITIGATION PLAN NOTES

OVERVIEW

A COMPREHENSIVE FIVE-YEAR MAINTENANCE AND MONITORING PLAN IS INCLUDED AS PART OF THE BUFFER ENHANCEMENT. THE PLAN SPECIFIES APPROPRIATE SPECIES FOR PLANTING AND PLANTING TECHNIQUES, DESCRIBES PROPER MAINTENANCE ACTIVITIES, AND SETS FORTH PERFORMANCE STANDARDS TO BE MET YEARLY DURING MONITORING. THIS WILL ENSURE THAT ENHANCEMENT/RESTORATION PLANTINGS WILL BE MAINTAINED, MONITORED, AND SUCCESSFULLY ESTABLISHED WITHIN THE FIRST FIVE YEARS FOLLOWING IMPLEMENTATION.

PROPOSED RESTORATION BEGINS WITH INCORPORATING COMPOST INTO THE ENHANCEMENT AREA. THIS WILL BE FOLLOWED BY INSTALLATION OF NATIVE TREE SHRUB AND GROUND COVER SPECIES SUITABLE TO THE SITE. TEN NATIVE SMALL TREE/SHRUB SPECIES AND FIVE NATIVE GROUND COVER SPECIES ARE PROPOSED IN THE MITIGATION AREA. THE PLAN CALLS FOR NEW PLANTINGS WITHIN THE INNER 25-FOOT SHORELINE BUFFER AREA AND THE WATERCOURSE BUFFER. NATIVE PLANTINGS ARE INTENDED TO INCREASE NATIVE PLANT COVER, IMPROVE NATIVE SPECIES DIVERSITY, INCREASE VEGETATIVE STRUCTURE, AND PROVIDE FOOD AND OTHER HABITAT RESOURCES FOR WILDLIFE.

GOALS

1. ENHANCE SHORELINE AND WATERCOURSE BUFFERS.
 - a. REDUCE THE AMOUNT OF IMPERVIOUS SURFACE AREA WITHIN WATERCOURSE BUFFERS.
 - b. ESTABLISH DENSE AND DIVERSE NATIVE SMALL TREE, SHRUB, AND GROUND COVER VEGETATION THROUGHOUT THE MITIGATION AREAS.

PERFORMANCE STANDARDS

THE STANDARDS LISTED BELOW WILL BE USED TO JUDGE THE SUCCESS OF THE PLAN OVER TIME. IF THE STANDARDS ARE MET AT THE END OF THE FIVE-YEAR MONITORING PERIOD, THE CITY SHALL ISSUE RELEASE OF THE PERFORMANCE BOND.

1. SURVIVAL:
 - a. 100% SURVIVAL OF ALL INSTALLED TREES AND SHRUBS AT THE END OF YEAR ONE. THIS STANDARD MAY BE MET THROUGH ESTABLISHMENT OF INSTALLED PLANTS OR BY REPLANTING AS NECESSARY TO ACHIEVE THE REQUIRED NUMBERS.
 - b. 80% SURVIVAL OF ALL INSTALLED TREES AND SHRUBS AT THE END OF YEAR TWO. THIS STANDARD MAY BE MET THROUGH ESTABLISHMENT OF INSTALLED PLANTS OR BY REPLANTING AS NECESSARY TO ACHIEVE THE REQUIRED NUMBERS.
 - c. SURVIVAL BEYOND YEAR TWO IS DIFFICULT TO TRACK. THEREFORE, A DIVERSITY STANDARD IS PROPOSED IN PLACE OF SURVIVAL (SEE #3, BELOW).
2. NATIVE VEGETATION COVER IN PLANTED AREAS:
 - a. ACHIEVE AT LEAST 60% COVER OF NATIVE PLANTS BY THE END OF YEAR 3. VOLUNTEER SPECIES MAY COUNT TOWARD THIS STANDARD. TOTAL NATIVE PLANT COVER MUST INCLUDE A MINIMUM OF 40% TREE AND SHRUB COVER.
 - b. ACHIEVE AT LEAST 80% COVER OF NATIVE PLANTS BY THE END OF YEAR 5. VOLUNTEER SPECIES MAY COUNT TOWARD THIS STANDARD. TOTAL NATIVE PLANT COVER MUST INCLUDE A MINIMUM OF 60% TREE AND SHRUB COVER.
3. SPECIES DIVERSITY IN PLANTED AREAS:
 - a. ESTABLISH AT LEAST SIX NATIVE SMALL TREE/SHRUB SPECIES AND FOUR NATIVE GROUND COVER SPECIES THROUGHOUT THE ENHANCEMENT AREAS BY YEAR 5. VOLUNTEER SPECIES MAY COUNT TOWARD THIS STANDARD. "ESTABLISHMENT" IS CONSIDERED AT LEAST FIVE HEALTHY, INDIVIDUAL PLANTS OF A GIVEN SPECIES PRESENT WITHIN THE MITIGATION AREAS.
4. INVASIVE SPECIES STANDARD: NO MORE THAN 10% COVER OF INVASIVE SPECIES IN THE PLANTING AREA IN ANY MONITORING YEAR. INVASIVE SPECIES ARE DEFINED AS ANY CLASS A, B, OR C NOXIOUS WEEDS AS LISTED BY THE KING COUNTY NOXIOUS WEED CONTROL BOARD.

MONITORING METHODS

THIS MONITORING PROGRAM IS DESIGNED TO TRACK THE SUCCESS OF THE MITIGATION SITE OVER TIME BY MEASURING THE DEGREE TO WHICH THE PERFORMANCE STANDARDS LISTED ABOVE ARE BEING MET. AN AS-BUILT PLAN WILL BE PREPARED WITHIN 30 DAYS OF SUBSTANTIALLY COMPLETE CONSTRUCTION OF THE MITIGATION AREAS. THE AS-BUILT PLAN

WILL DOCUMENT CONFORMANCE WITH THESE PLANS AND WILL DISCLOSE ANY SUBSTITUTIONS OR OTHER NON-CRITICAL DEPARTURES. THE AS-BUILT PLAN WILL ESTABLISH BASELINE PLANT INSTALLATION QUANTITIES, PHOTOPPOINTS, AND THREE 50-FOOT MONITORING TRANSECTS THAT WILL BE USED THROUGHOUT THE MONITORING PERIOD TO MEASURE THE PERFORMANCE STANDARDS.

MONITORING WILL OCCUR TWICE ANNUALLY FOR FIVE YEARS. THE FIRST MONITORING VISIT WILL TAKE PLACE IN THE SPRING. THIS VISIT WILL RECORD NECESSARY WEEDING, INVASIVE CONTROL, AND OTHER MAINTENANCE NEEDS. THE RESTORATION SPECIALIST WILL THEN NOTIFY THE OWNER AND/OR MAINTENANCE CREWS OF NECESSARY EARLY SEASON MAINTENANCE. THE LATE-SEASON VISIT WILL OCCUR IN LATE SUMMER OR FALL AND WILL RECORD THE FOLLOWING AND BE SUBMITTED IN AN ANNUAL REPORT TO THE CITY:

1. GENERAL SUMMARY OF THE SPRING VISIT.
2. FIRST- AND SECOND-YEAR COUNTS OF SURVIVING AND DEAD/DYING PLANTS BY SPECIES IN THE PLANTING AREAS.
3. ESTIMATES OF NATIVE SPECIES COVER USING COVER CLASS METHOD.
4. ESTIMATES OF INVASIVE SPECIES COVER USING COVER CLASS METHOD.
5. COUNTS OF ESTABLISHED NATIVE SPECIES TO DETERMINE SPECIES RICHNESS.
6. PHOTOGRAPHIC DOCUMENTATION AT PERMANENT PHOTOPPOINTS.
7. INTRUSIONS INTO THE PLANTING AREAS, EROSION, VANDALISM, TRASH, AND OTHER ACTIONS DETRIMENTAL TO THE OVERALL HEALTH OF THE MITIGATION AREAS.
8. RECOMMENDATIONS FOR MAINTENANCE IN THE MITIGATION AREAS.
9. RECOMMENDATIONS FOR REPLACEMENT OF ALL DEAD OR DYING PLANT MATERIAL WITH SAME OR LIKE SPECIES AND NUMBER AS ON THE APPROVED PLAN.

CONSTRUCTION NOTES AND SPECIFICATIONS

GENERAL NOTES

THE RESTORATION SPECIALIST WILL OVERSEE THE FOLLOWING:

1. CLEARING, SOIL DECOMPACTION, AND COMPOST INCORPORATION;
2. INVASIVE WEED CLEARING; AND
3. PLANT MATERIAL INSPECTION.
 - a) PLANT DELIVERY INSPECTION.
 - b) 50% PLANT INSTALLATION/LAYOUT INSPECTION.
 - c) 100% PLANT INSTALLATION INSPECTION.

WORK SEQUENCE

1. CLEAR THE PLANTING AREA OF ALL INVASIVE WOODY VEGETATION INCLUDING BUT NOT LIMITED TO HIMALAYAN BLACKBERRY, ENGLISH IVY, AND ENGLISH LAUREL.
2. ROTO-TILL 3 INCHES OF COMPOST INTO THE UPPER 8 INCHES OF THE SOIL.
3. ALL PLANT INSTALLATION WILL TAKE PLACE DURING THE DORMANT SEASON (OCTOBER 15TH TO MARCH 1ST).
4. LAYOUT VEGETATION TO BE INSTALLED PER THE PLANTING PLAN AND PLANT SCHEDULE.
5. PREPARE A PLANTING PIT FOR EACH PLANT AND INSTALL PER THE PLANTING DETAILS.
6. MULCH EACH TREE AND SHRUB WITH A CIRCULAR WOOD CHIP MULCH RING, 4 INCHES THICK AND EXTENDING 9 INCHES FROM THE BASE OF THE PLANT (18-INCH DIAMETER).
7. INSTALL A TEMPORARY OR PERMANENT IRRIGATION SYSTEM AS NEEDED TO ENSURE THAT ALL PLANTS RECEIVE AT LEAST ONE INCH OF WATER PER WEEK FROM JUNE 1ST - SEPTEMBER 30TH. MAINTAIN IRRIGATION SYSTEM IN WORKING CONDITION FOR AT LEAST TWO SUMMERS AFTER INITIAL PLANT INSTALLATION.

MAINTENANCE

THIS SITE WILL BE MAINTAINED FOR FIVE YEARS FOLLOWING COMPLETION OF THE PLANT INSTALLATION.

1. REPLACE EACH PLANT FOUND DEAD IN THE SUMMER MONITORING VISIT DURING THE UPCOMING FALL DORMANT SEASON (OCTOBER 15TH TO MARCH 1ST).
2. FOLLOW THE RECOMMENDATIONS NOTED IN THE SPRING MONITORING SITE VISIT.
3. INVASIVE SPECIES MAINTENANCE PLAN:
 - a) HIMALAYAN BLACKBERRY, ENGLISH IVY, ENGLISH LAUREL, AND OTHER INVASIVE WOODY VEGETATION WILL BE GRUBBED OUT BY HAND ON AN ONGOING BASIS, WITH CARE TAKEN TO GRUB OUT ROOTS EXCEPT WHERE SUCH WORK WILL JEOPARDIZE THE ROOTS OF INSTALLED OR VOLUNTEER NATIVE PLANTS.
 - b) IF IT IS LIKELY THAT HAND REMOVAL WILL NOT BE COMPLETELY EFFECTIVE OR WILL DAMAGE DESIRABLE SPECIES, THEN APPLICATION OF AN HERBICIDE APPROVED FOR USE IN AQUATIC AREAS MAY BE USED. HERBICIDE APPLICATIONS MUST BE CONDUCTED ONLY BY A STATE-LICENSED APPLICATOR. APPLICATIONS SHOULD BE DONE BETWEEN MID-SPRING AND MID-SUMMER TO MAXIMIZE UPTAKE BY PLANTS. APPLICATION SHOULD BE A TARGETED METHOD SUCH AS SPOT SPRAY (PREFERRED FOR HIMALAYAN BLACKBERRY), OR WICK.
4. AT LEAST TWICE YEARLY, REMOVE BY HAND ALL COMPETING WEEDS AND WEED ROOTS FROM BENEATH EACH INSTALLED PLANT AND ANY DESIRABLE VOLUNTEER VEGETATION TO A DISTANCE OF 12 INCHES FROM THE MAIN PLANT STEM. WEEDING SHOULD OCCUR AS NEEDED DURING THE SPRING AND SUMMER. FREQUENT WEEDING WILL RESULT IN LOWER MORTALITY AND LOWER PLANT REPLACEMENT COSTS.
5. DO NOT WEED THE AREA NEAR THE PLANT BASES WITH STRING TRIMMER (WEED WHACKER). NATIVE PLANTS ARE EASILY DAMAGED OR KILLED, AND WEEDS EASILY RECOVER AFTER TRIMMING.
6. MULCH THE WEEDED AREAS BENEATH EACH PLANT WITH WOOD CHIP MULCH AS NECESSARY TO MAINTAIN A MINIMUM 4-INCH-THICK, 18-INCH-DIAMETER MULCH RING.
7. THE TEMPORARY IRRIGATION SYSTEM WILL BE OPERATED TO ENSURE THAT PLANTS RECEIVE A MINIMUM OF ONE INCH OF WATER PER WEEK FROM JUNE 1ST THROUGH SEPTEMBER 30TH FOR THE FIRST TWO YEARS FOLLOWING INSTALLATION. IRRIGATION BEYOND THE SECOND YEAR MAY BE NEEDED BASED ON SITE PERFORMANCE OR SIGNIFICANT REPLANTING.

MATERIAL SPECIFICATIONS AND DEFINITIONS

1. COMPOST: CEDAR GROVE COMPOST OR EQUIVALENT PRODUCT. 100% VEGETABLE COMPOST WITH NO APPRECIABLE QUANTITIES OF SAND, GRAVEL, SAWDUST, OR OTHER NON-ORGANIC MATERIALS. QUANTITY REQUIRED: 56 CUBIC YARDS.
2. RESTORATION SPECIALIST: THE WATERSHED COMPANY [(425) 822-5242] PERSONNEL OR OTHER PERSON QUALIFIED TO EVALUATE ENVIRONMENTAL RESTORATION PROJECTS.
3. WOOD CHIP MULCH: CHIPPED WOODY MATERIAL APPROXIMATELY 1 INCH MINIMUM TO 3 INCHES IN MAXIMUM DIMENSION (NOT SAWDUST OR COARSE HOG FUEL). MULCH SHALL NOT CONTAIN APPRECIABLE QUANTITIES OF GARBAGE, PLASTIC, METAL, SOIL, AND DIMENSIONAL LUMBER OR CONSTRUCTION/ DEMOLITION DEBRIS. PACIFIC TOPSOIL [(800) 844-7645] SELLS SUITABLE WOODCHIP MULCH CALLED "WOOD CHIP MULCH" AT MANY OF THEIR LOCATIONS. NOTE: ARBORIST WOODCHIPS GENERALLY CONTAIN WEED SEEDS AND ARE NOT A RELIABLE ALTERNATIVE. QUANTITY REQUIRED: 4 CUBIC YARDS.



750 Sixth Street South
Kirkland WA 98033

p 425.822.5242
www.watershedco.com

Science & Design

YANG RESIDENCE
BUFFER AVERAGING PLAN
PREPARED FOR
STEVE AND SOPHIE YANG
 6660 EAST MERCER WAY
 MERCER ISLAND, WA 98040

SUBMITTALS & REVISIONS		NO.	DATE	DESCRIPTION	BY
1	07-11-2019	REVIEW SET	GM		
2	10-04-2019	REVISIONS TO CITY COMMENTS	AAM		

SHEET SIZE:
ORIGINAL PLAN IS 22" x 34".
SCALE ACCORDINGLY.

PROJECT MANAGER: RK
DESIGNED: RK/KMB/GM
DRAFTED: GM
CHECKED: RK/KMB

JOB NUMBER:
180605

SHEET NUMBER:
W7 OF 7



Know what's below.
Call before you dig.

MITIGATION PLAN NOTES

APPENDIX B

Bond Quantity Worksheet



Department of Permitting

Environmental Review
35030 SE Douglas Str, Suite 210
Snoqualmie, WA 98065-9266
206-296-6600 TTY Relay: 711

**Critical Areas Mitigation
Bond Quantity Worksheet**

C24 09/09/2015
ls-wks-sensareaBQ.xls
ls-wks-sensareaBQ.pdf

King County

Project Name: Mercer Island Yang **Date:** 4-Oct-19 **Prepared by:** Kahlo, Ryan

Project Number: **Project Description:** Watercourse Buffer Averaging

Location: 6660 East Mercer Way, Mercer Island, WA **Applicant:** Steve and Sophie Yang **Phone:** 206-406-6954

PLANT MATERIALS (includes labor cost for plant installation)

Type	Unit Price	Unit	Quantity	Description	Cost
PLANTS: Potted, 4" diameter, medium	\$5.00	Each	741.00		\$ 3,705.00
PLANTS: Container, 1 gallon, medium soil	\$11.50	Each	379.00		\$ 4,358.50
PLANTS: Container, 2 gallon, medium soil	\$20.00	Each			\$ -
PLANTS: Container, 5 gallon, medium soil	\$36.00	Each			\$ -
PLANTS: Seeding, by hand	\$0.50	SY			\$ -
PLANTS: Slips (willow, red-osier)	\$2.00	Each			\$ -
PLANTS: Stakes (willow)	\$2.00	Each			\$ -
PLANTS: Stakes (willow)	\$2.00	Each			\$ -
PLANTS: Flats/plugs	\$2.00	Each			\$ -
TOTAL					\$ 8,063.50

INSTALLATION COSTS (LABOR, EQUIPMENT, & OVERHEAD)

Type	Unit Price	Unit	Quantity	Description	Cost
Compost, vegetable, delivered and spread	\$37.88	CY	56.00		\$ 2,121.28
Decompacting till/hardpan, medium, to 6" depth	\$1.57	CY	56.00		\$ 87.92
Decompacting till/hardpan, medium, to 12" depth	\$1.57	CY			\$ -
Hydroseeding	\$0.51	SY			\$ -
Labor, general (landscaping other than plant installation)	\$40.00	HR			\$ -
Labor, general (construction)	\$40.00	HR			\$ -
Labor: Consultant, supervising	\$55.00	HR			\$ -
Labor: Consultant, on-site re-design	\$95.00	HR			\$ -
Rental of decompacting machinery & operator	\$70.00	HR	6.00		\$ 420.00
Sand, coarse builder's, delivered and spread	\$42.00	CY			\$ -
Staking material (set per tree)	\$7.00	Each			\$ -
Surveying, line & grade	\$250.00	HR			\$ -
Surveying, topographical	\$250.00	HR			\$ -
Watering, 1" of water, 50' soaker hose	\$3.62	MSF			\$ -
Irrigation - temporary	\$3,000.00	Acre	0.10		\$ 300.00
Irrigation - buried	\$4,500.00	Acre			\$ -
Tilling topsoil, disk harrow, 20hp tractor, 4"-6" deep	\$1.02	SY			\$ -
TOTAL					\$ 2,929.20

HABITAT STRUCTURES*

ITEMS	Unit Cost	Unit	Quantity	Description	Cost
Fascines (willow)	\$ 2.00	Each			\$ -
Logs, (cedar), w/ root wads, 16"-24" diam., 30' long	\$1,000.00	Each			\$ -
Logs (cedar) w/o root wads, 16"-24" diam., 30'	\$400.00	Each			\$ -
Logs, w/o root wads, 16"-24" diam., 30' long	\$245.00	Each			\$ -
Logs w/ root wads, 16"-24" diam., 30' long	\$460.00	Each			\$ -
Rocks, one-man	\$60.00	Each			\$ -
Rocks, two-man	\$120.00	Each			\$ -
Root wads	\$163.00	Each			\$ -
Spawning gravel, type A	\$22.00	CY			\$ -
Weir - log	\$1,500.00	Each			\$ -
Weir - adjustable	\$2,000.00	Each			\$ -
Woody debris, large	\$163.00	Each			\$ -
Snags - anchored	\$400.00	Each			\$ -
Snags - on site	\$50.00	Each			\$ -
Snags - imported	\$800.00	Each			\$ -
TOTAL					\$ -

* All costs include delivery and installation

EROSION CONTROL

ITEMS	Unit Cost	Unit	Quantity	Description	Cost
Backfill and Compaction-embankment	\$ 4.89	CY			\$ -
Crushed surfacing, 1 1/4" minus	\$30.00	CY			\$ -
Ditching	\$7.03	CY			\$ -
Excavation, bulk	\$4.00	CY			\$ -
Fence, silt	\$1.60	LF	73.00		\$ 116.80
Jute Mesh	\$1.26	SY			\$ -
Mulch, by hand, straw, 2" deep	\$1.27	SY			\$ -
Mulch, by hand, wood chips, 2" deep	\$3.25	SY	290.00		\$ 942.50
Mulch, by machine, straw, 1" deep	\$0.32	SY			\$ -
Piping, temporary, CPP, 6"	\$9.30	LF			\$ -

Piping, temporary, CPP, 8"	\$14.00	LF		\$	-
Piping, temporary, CPP, 12"	\$18.00	LF		\$	-
Plastic covering, 6mm thick, sandbagged	\$2.00	SY		\$	-
Rip Rap, machine placed, slopes	\$33.98	CY		\$	-
Rock Constr. Entrance 100'x15'x1'	\$3,000.00	Each		\$	-
Rock Constr. Entrance 50'x15'x1'	\$1,500.00	Each		\$	-
Sediment pond riser assembly	\$1,695.11	Each		\$	-
Sediment trap, 5' high berm	\$15.57	LF		\$	-
Sediment trap, 5' high berm w/spillway incl. riprap	\$59.60	LF		\$	-
Sodding, 1" deep, level ground	\$5.24	SY		\$	-
Sodding, 1" deep, sloped ground	\$6.48	SY		\$	-
Straw bales, place and remove	\$600.00	TON		\$	-
Hauling and disposal	\$20.00	CY		\$	-
Topsoil, delivered and spread	\$35.73	CY		\$	-
				TOTAL	\$ 1,059.30

GENERAL ITEMS

ITEMS	Unit Cost	Unit		Cost	
Fencing, chain link, 6' high	\$18.89	LF		\$ -	
Fencing, chain link, corner posts	\$111.17	Each		\$ -	
Fencing, chain link, gate	\$277.63	Each		\$ -	
Fencing, split rail, 3' high (2-rail)	\$10.54	LF		\$ -	
Fencing, temporary (NGPE)	\$1.20	LF		\$ -	
Signs, sensitive area boundary (inc. backing, post, install)	\$28.50	Each		\$ -	
				TOTAL	\$ -

OTHER

(Construction Cost Subtotal) **\$ 12,052.00**

ITEMS	Percentage of Construction	Unit		Cost	
Mobilization	10%	1		\$ 1,205.20	
Contingency	30%	1		\$ 3,615.60	
				TOTAL	\$ 4,820.80

MAINTENANCE AND MONITORING

NOTE: Projects with multiple permit requirements may be required to have longer monitoring and maintenance terms. This will be evaluated on a case-by-case basis for development applications. Monitoring and maintenance ranges may be assessed anywhere from 5 to 10 years.

Maintenance, annual (by owner or consultant)					
Less than 1,000 sq.ft. and buffer mitigation only	\$ 1.08	SF	(3 X SF total for 3 annual events; Includes monitoring)	\$ -	
Less than 1,000 sq.ft. with wetland or aquatic area mitigation	\$ 1.35	SF	(3 X SF total for 3 annual events; Includes monitoring)	\$ -	
Larger than 1,000 sq. ft. but less than 5,000 sq.ft. of buffer mitigation	\$ 180.00	EACH	5.00 (4hr @\$45/hr)	\$ 900.00	
Larger than 1,000 sq. ft. but less than 5,000 sq.ft. of wetland or aquatic area mitigation	\$ 270.00	EACH	(6hr @\$45/hr)	\$ -	
Larger than 5,000 sq.ft. but < 1 acre -buffer mitigation only	\$ 360.00	EACH	(8 hrs @ 45/hr)	\$ -	
Larger than 5,000 sq.ft. but < 1 acre with wetland or aquatic area mitigation	\$ 450.00	EACH	(10 hrs @ \$45/hr)	\$ -	
Larger than 1 acre but < 5 acres - buffer and / or wetland or aquatic area mitigation	\$ 1,600.00	DAY	(WEC crew)	\$ -	
Larger than 5 acres - buffer and / or wetland or aquatic area mitigation	\$ 2,000.00	DAY	(1.25 X WEC crew)	\$ -	
Monitoring, annual (by owner or consultant)					
Larger than 1,000 sq.ft. but less than 5,000 wetland or buffer mitigation	\$ 720.00	EACH	5.00 (8 hrs @ 90/hr)	\$ 3,600.00	
Larger than 5,000 sq.ft. but < 1 acre with wetland or aquatic area impacts	\$ 900.00	EACH	(10 hrs @ \$90/hr)	\$ -	
Larger than 1 acre but < 5 acres - buffer and / or wetland or aquatic area impacts	\$ 1,440.00	DAY	(16 hrs @ \$90/hr)	\$ -	
Larger than 5 acres - buffer and / or wetland or aquatic area impacts	\$ 2,160.00	DAY	(24 hrs @ \$90/hr)	\$ -	
				TOTAL	\$ 4,500.00

Total \$21,372.80